

Improvised Munitions Sketchbook

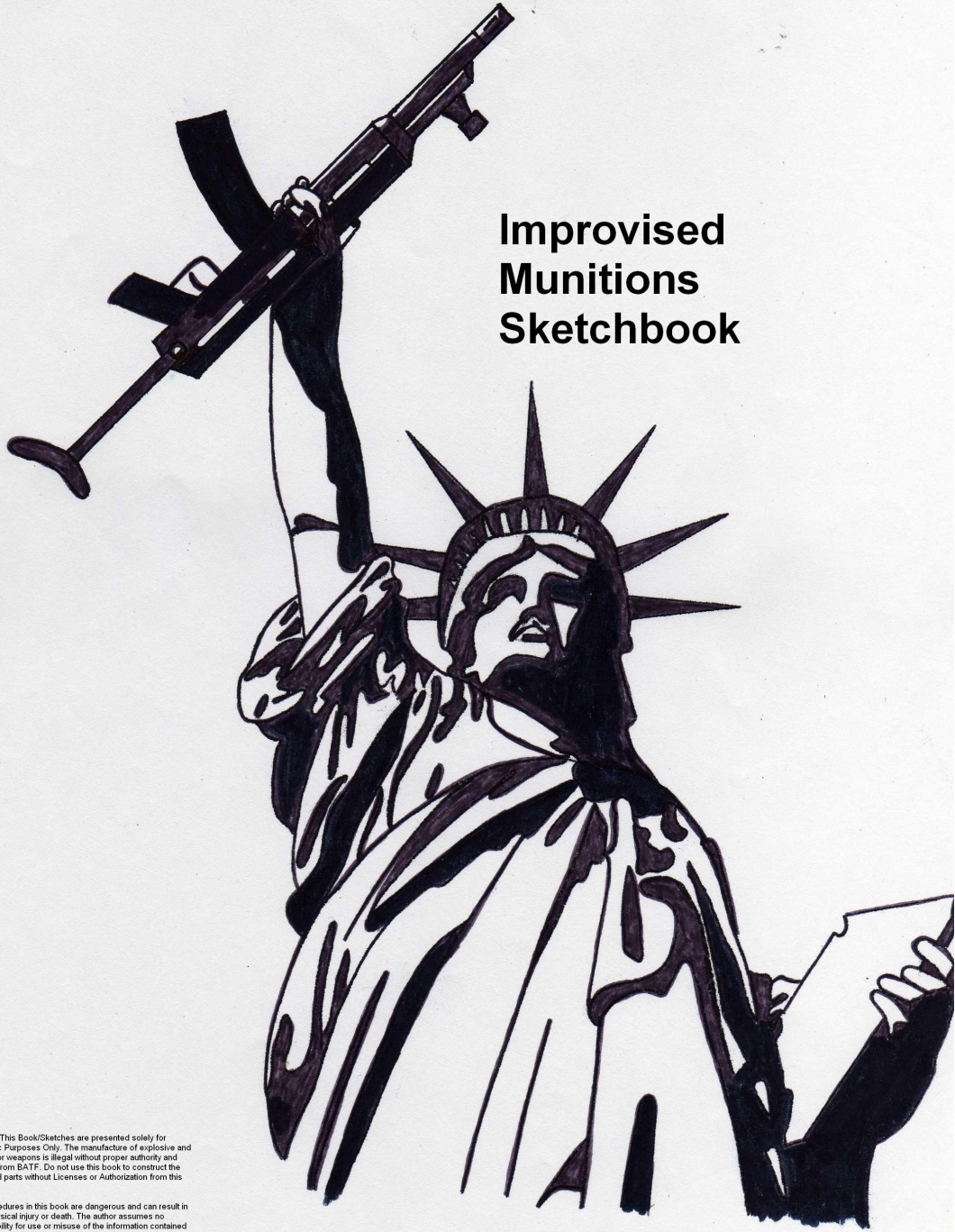

Warning: This Book/Sketches are presented solely for Academic Purposes Only. The manufacture of explosive and firearms or weapons is illegal without proper authority and licenses from BATF. Do not use this book to construct the described parts without Licenses or Authorization from this agency.

The procedures in this book are dangerous and can result in either physical injury or death. The author assumes no responsibility for use or misuse of the information contained herein.



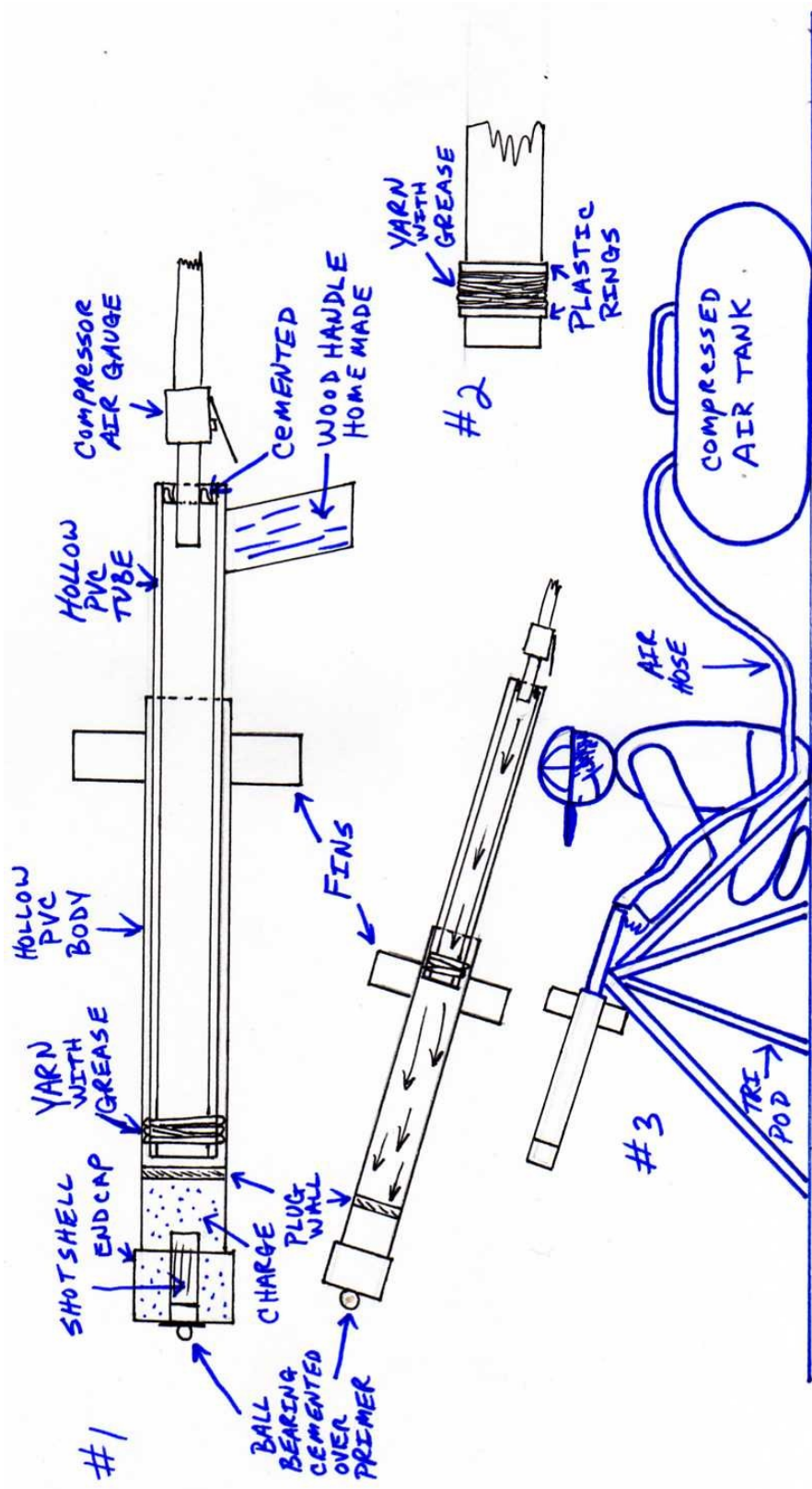

IMPROVED STOMP ROCKET

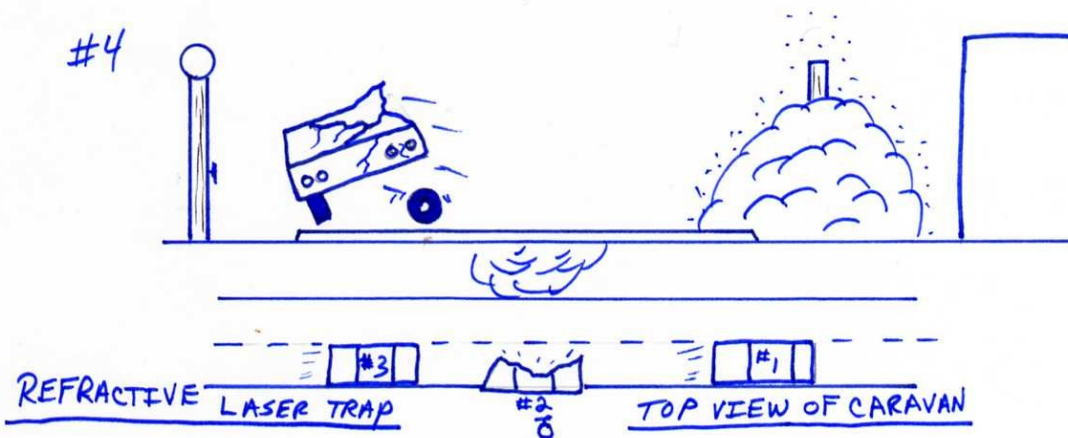
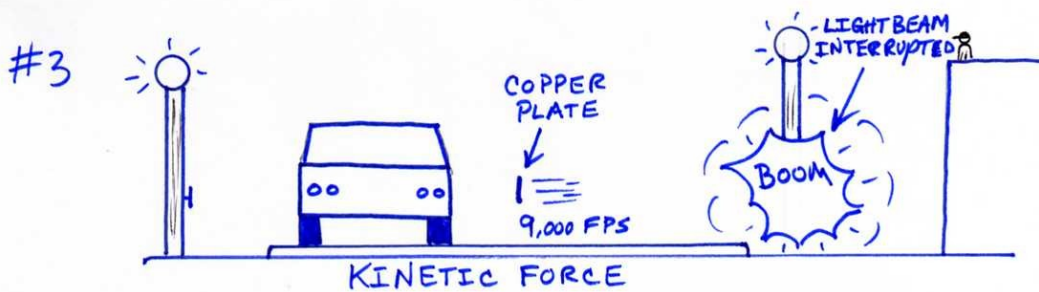
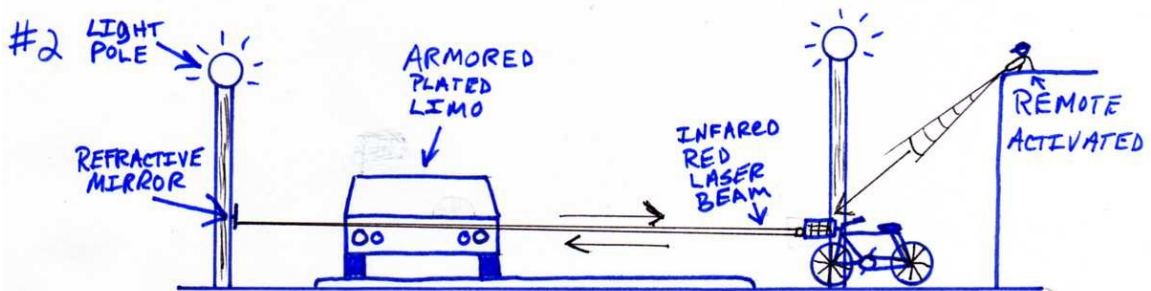
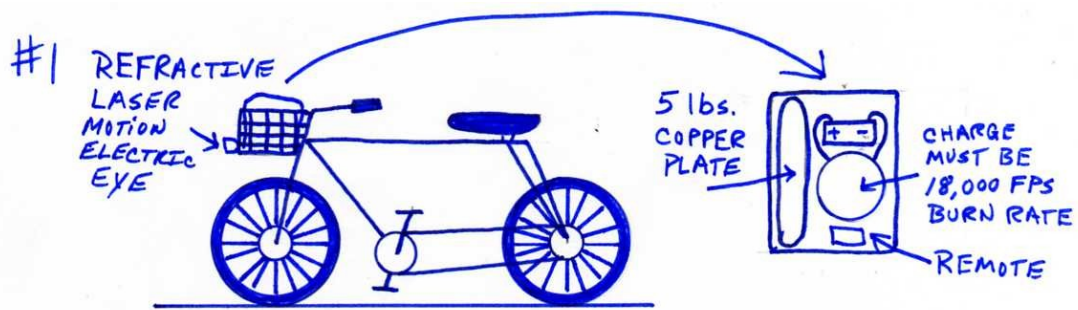

Remote Vehicle Attack

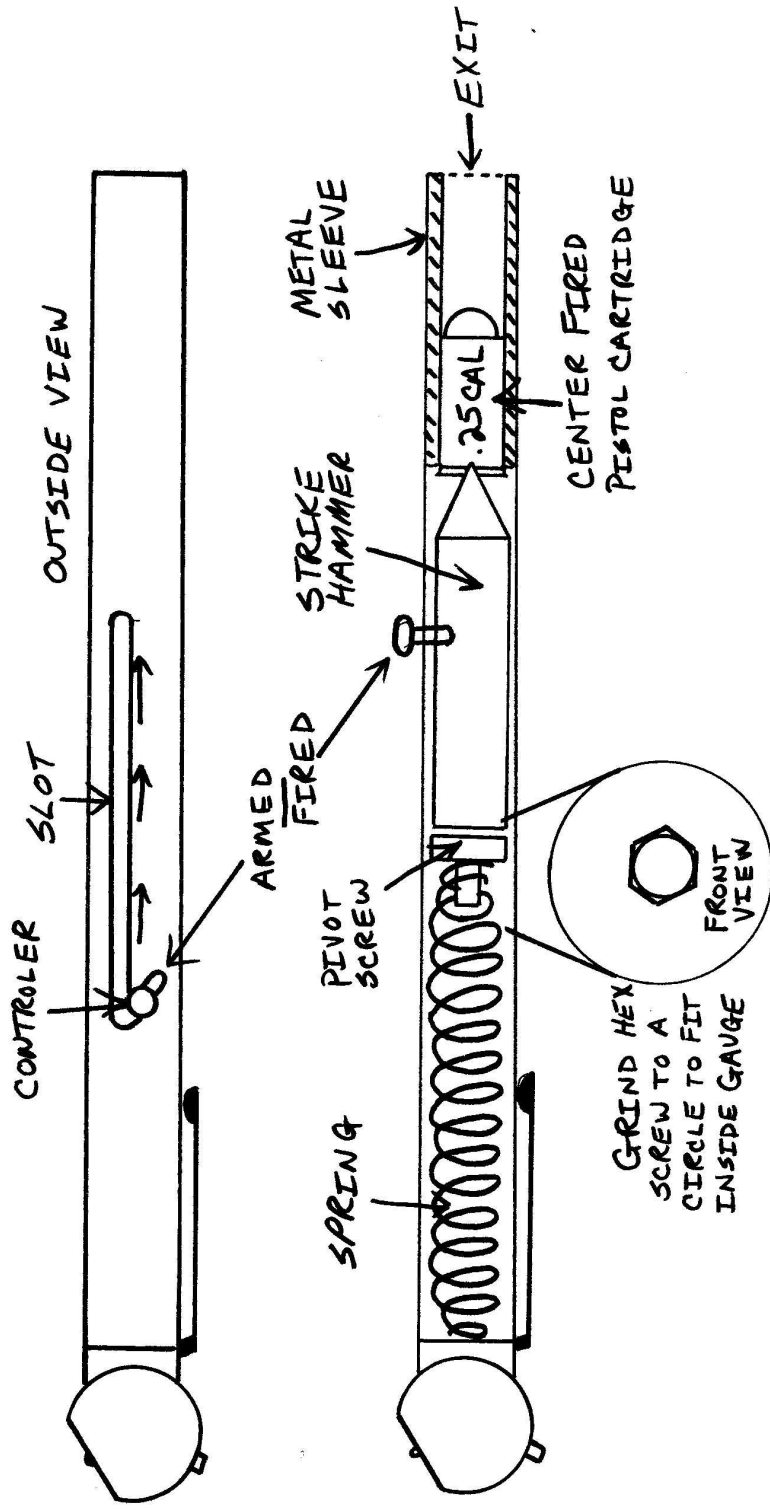

TIRE GAUGE GUN

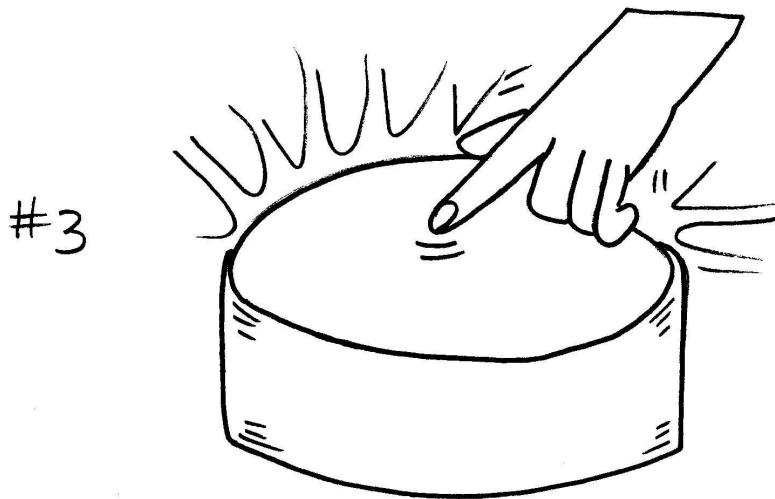
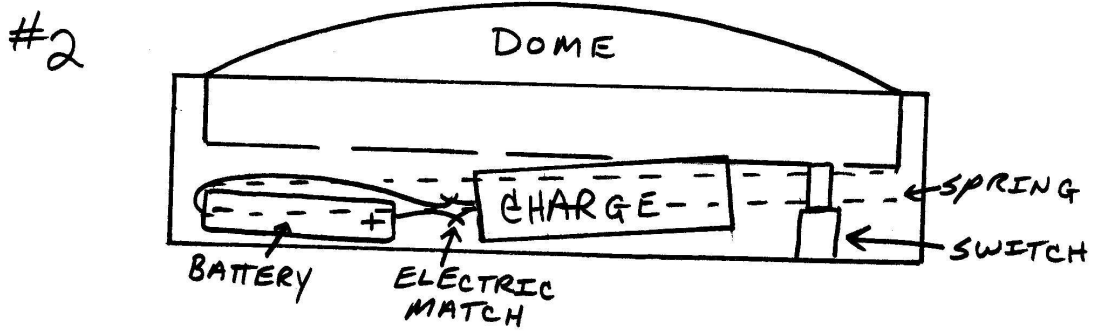
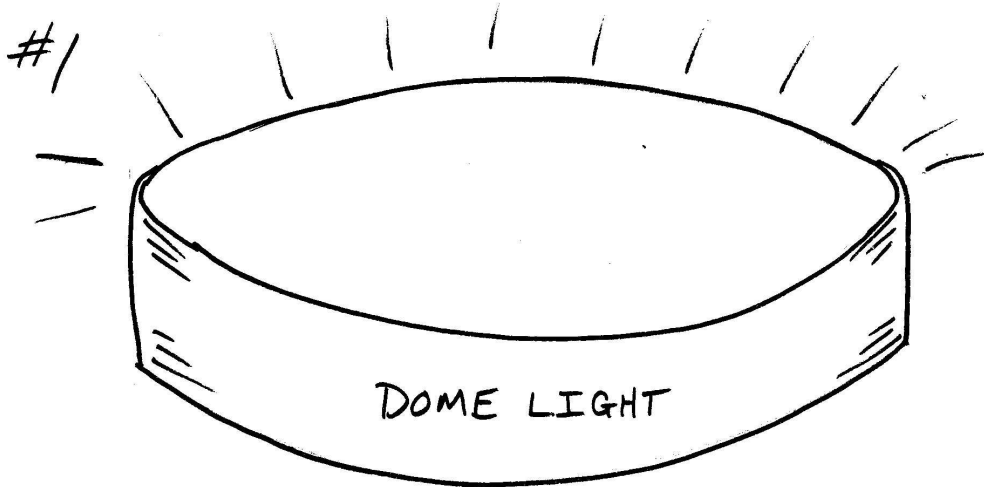

DOME LIGHT BOOBYTRAP

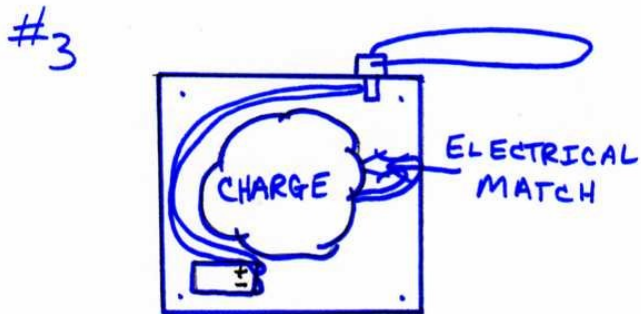
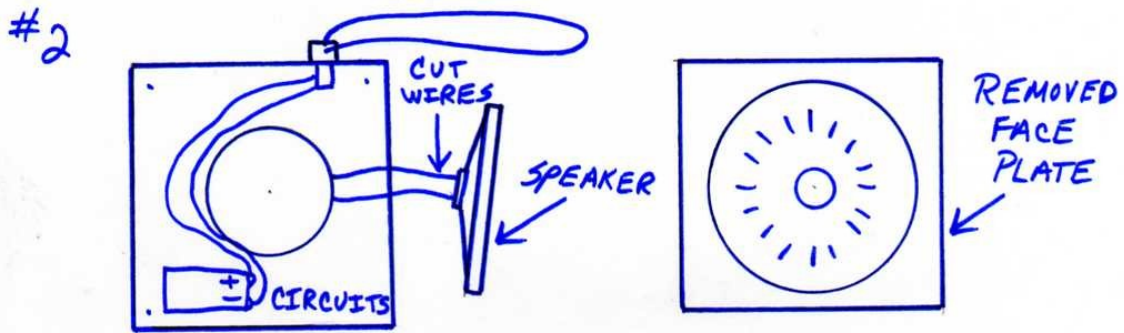
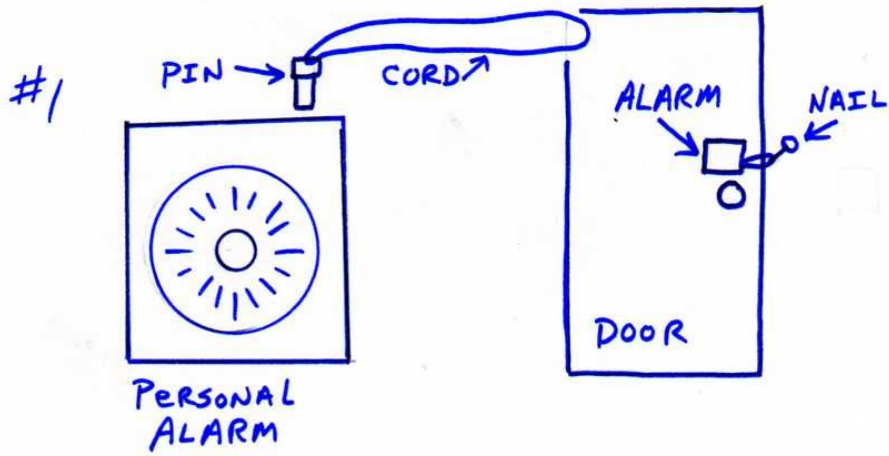

PERSONAL ALARM BOOBYTRAP

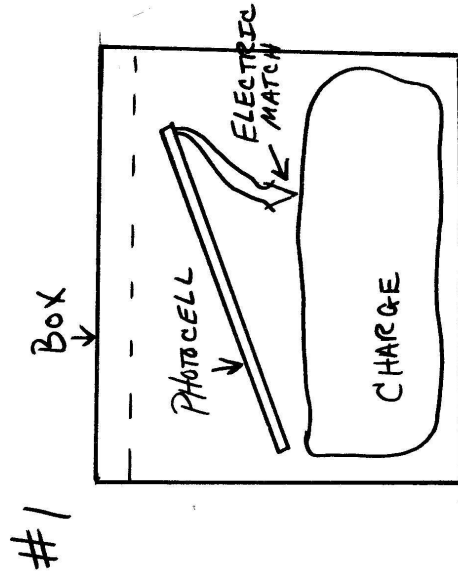
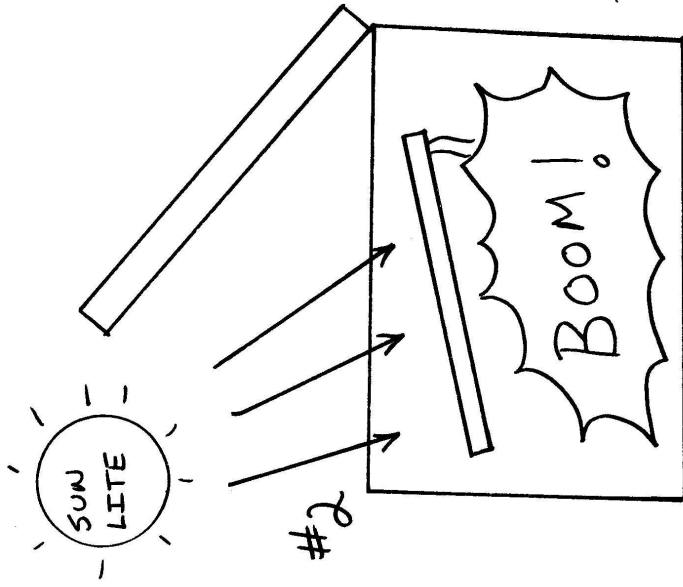

PHOTOCELL BOOBYTRAP

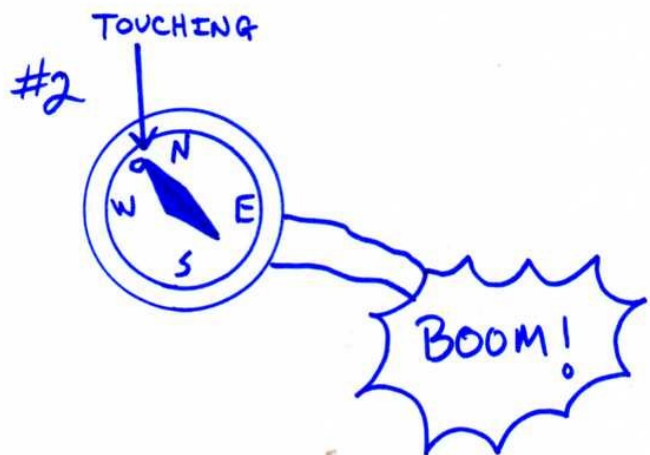
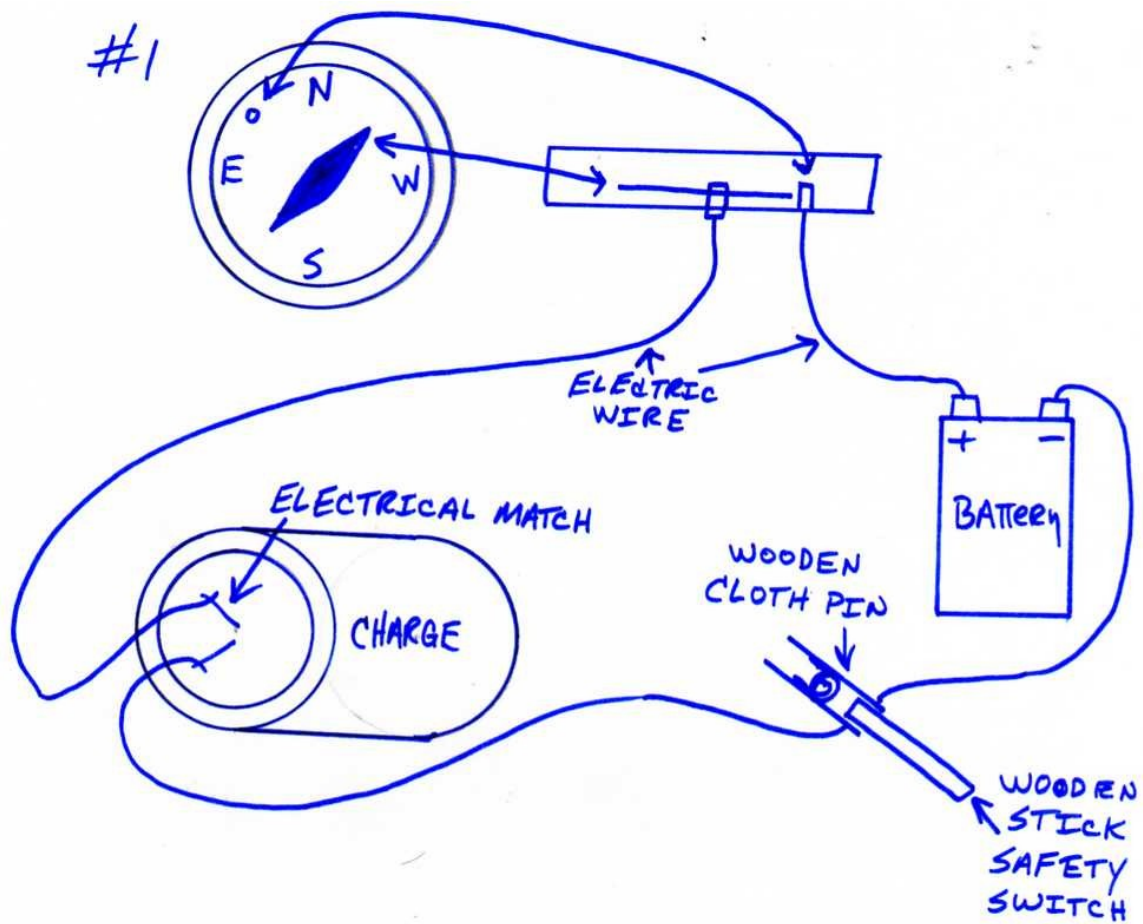

COMPASS SWITCH

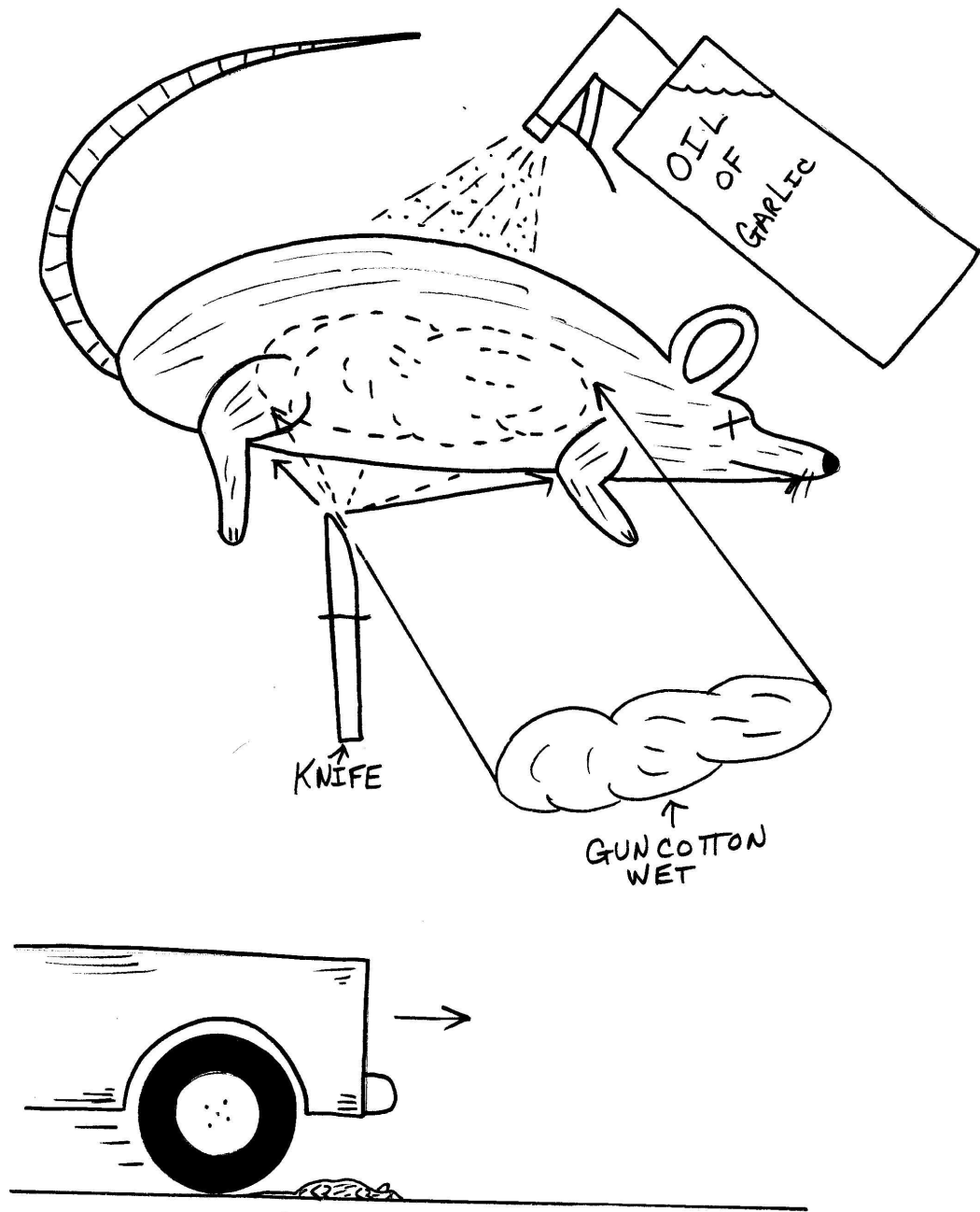

DEAD RAT MINE

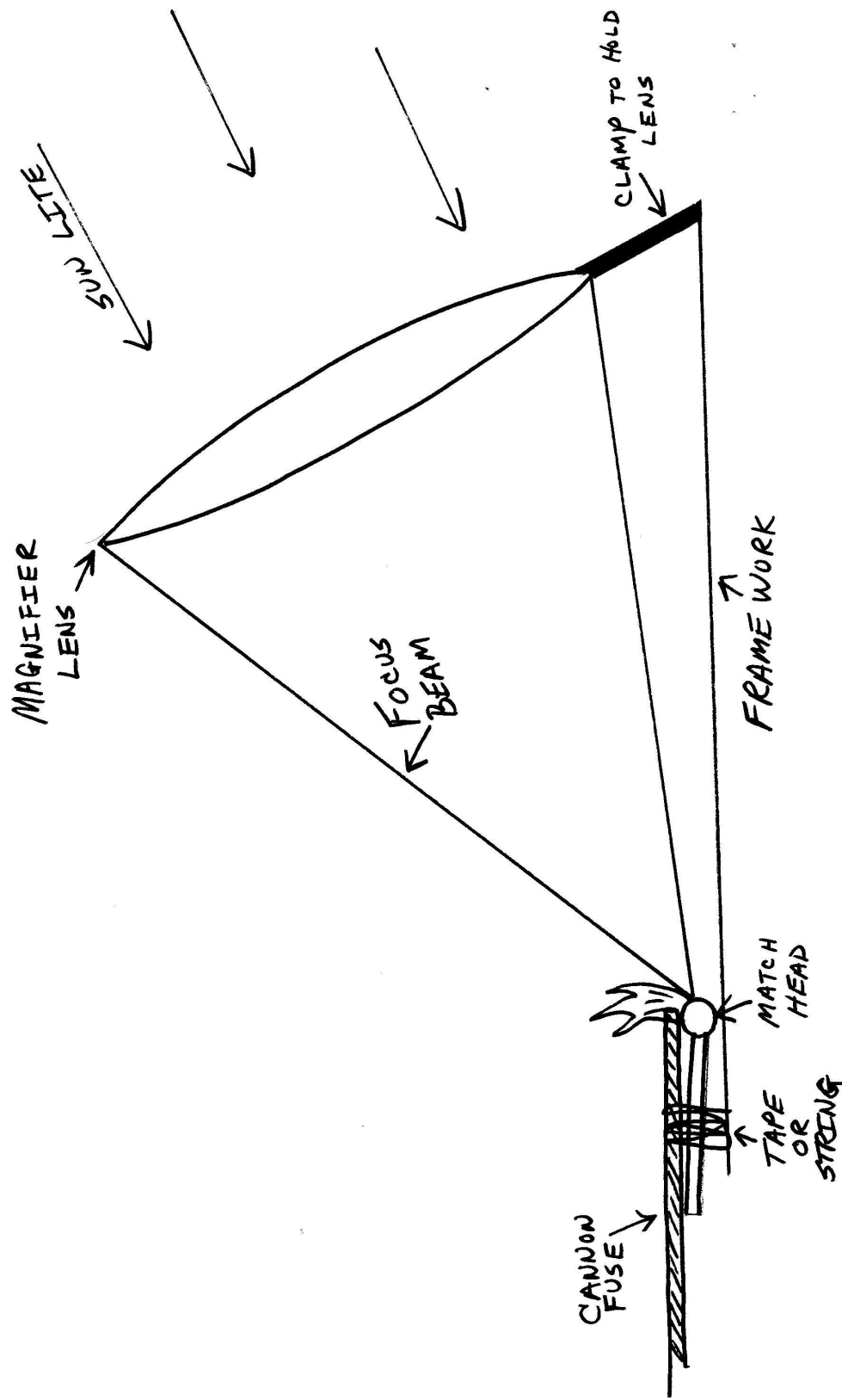

TIME DELAY LENS IGNITOR

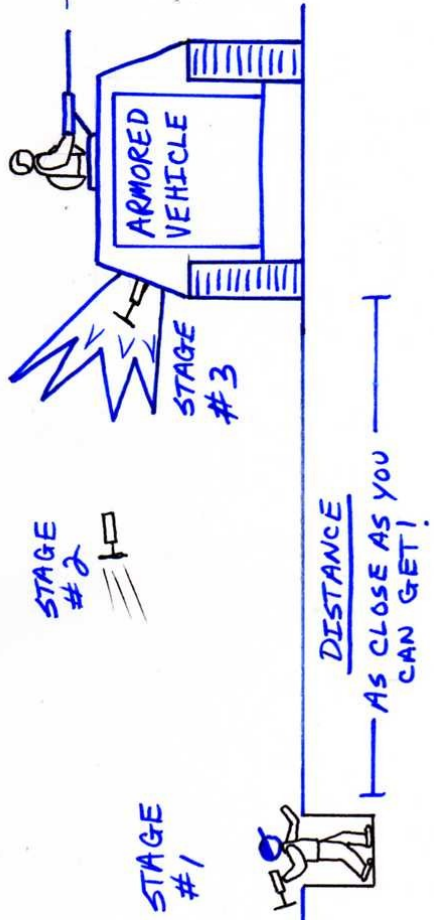
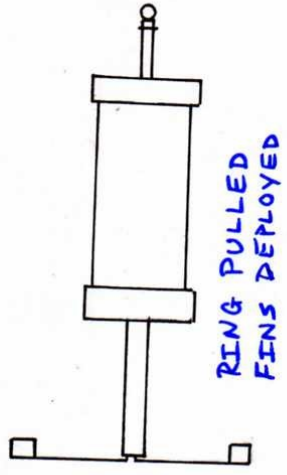
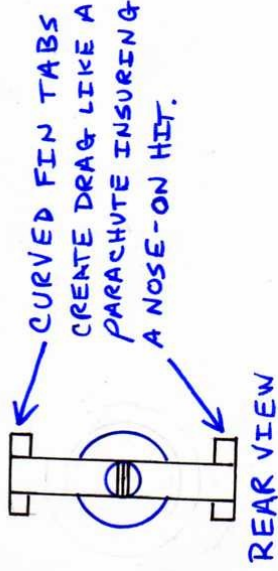
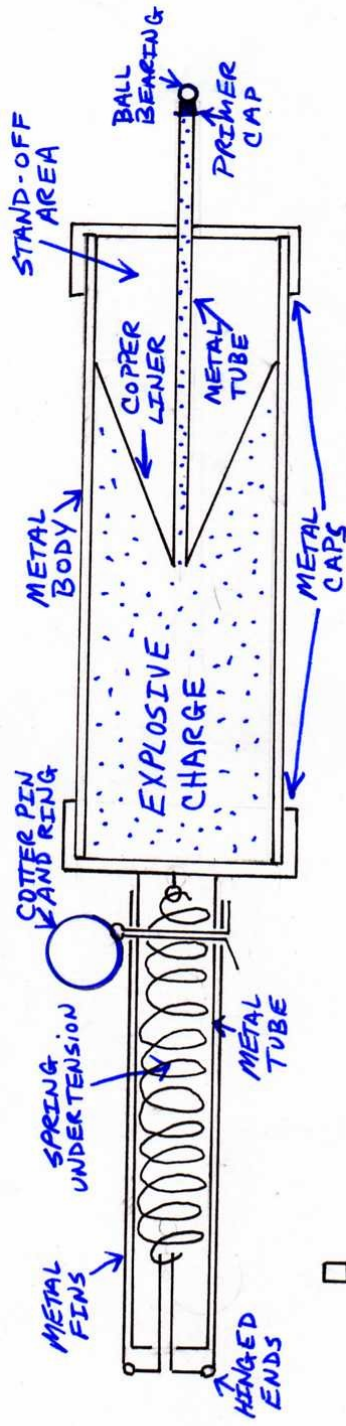

**ANTI-TANK GRENADE
LAST-DITCH INFANTRYMAN
WEAPON**

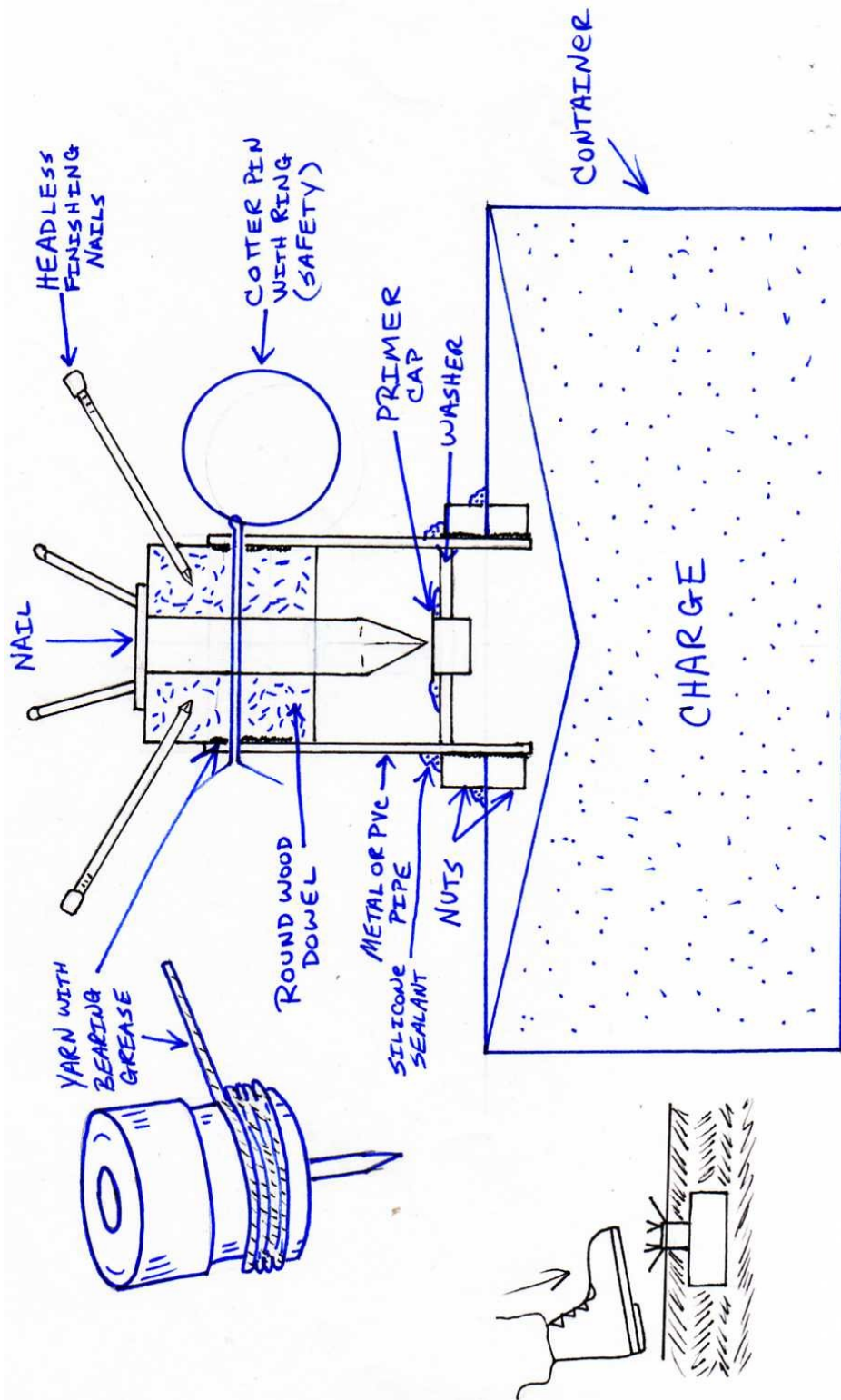

LAND MINE

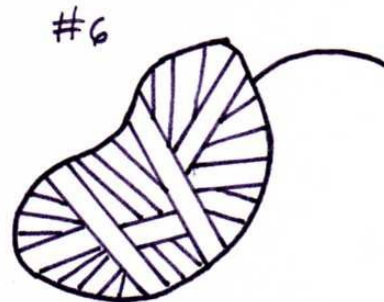
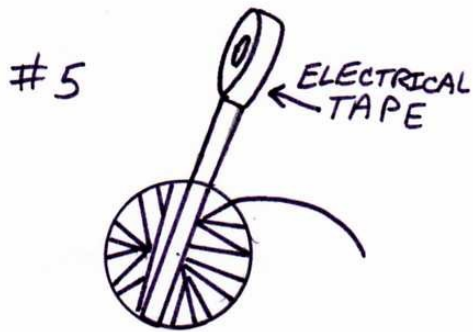
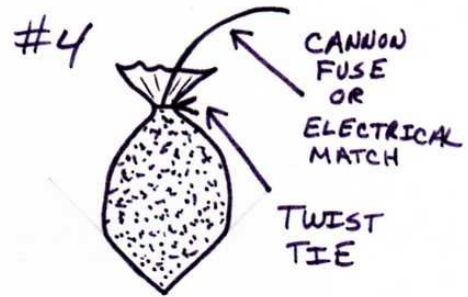
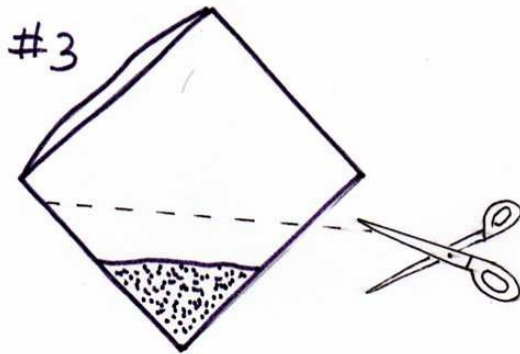
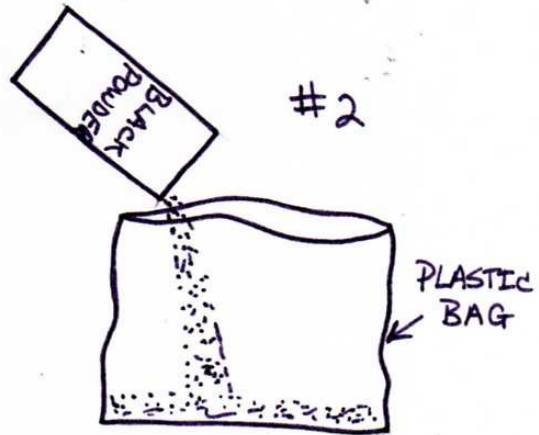
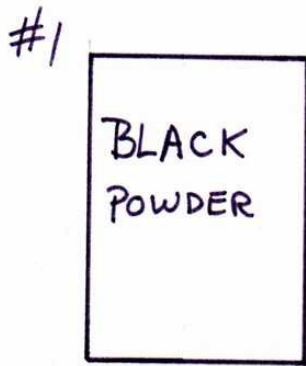

IMPROVED BLACK POWER CHARGE

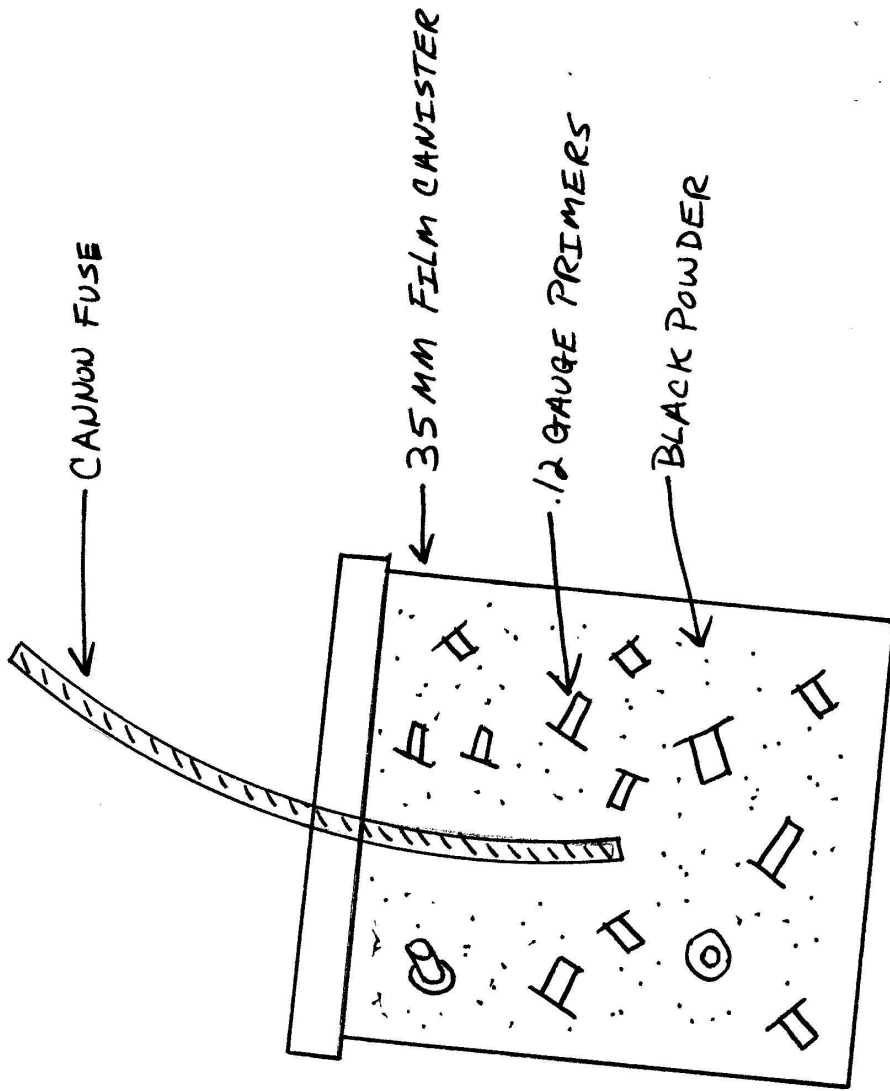

HOMEMADE BLASTING CAP

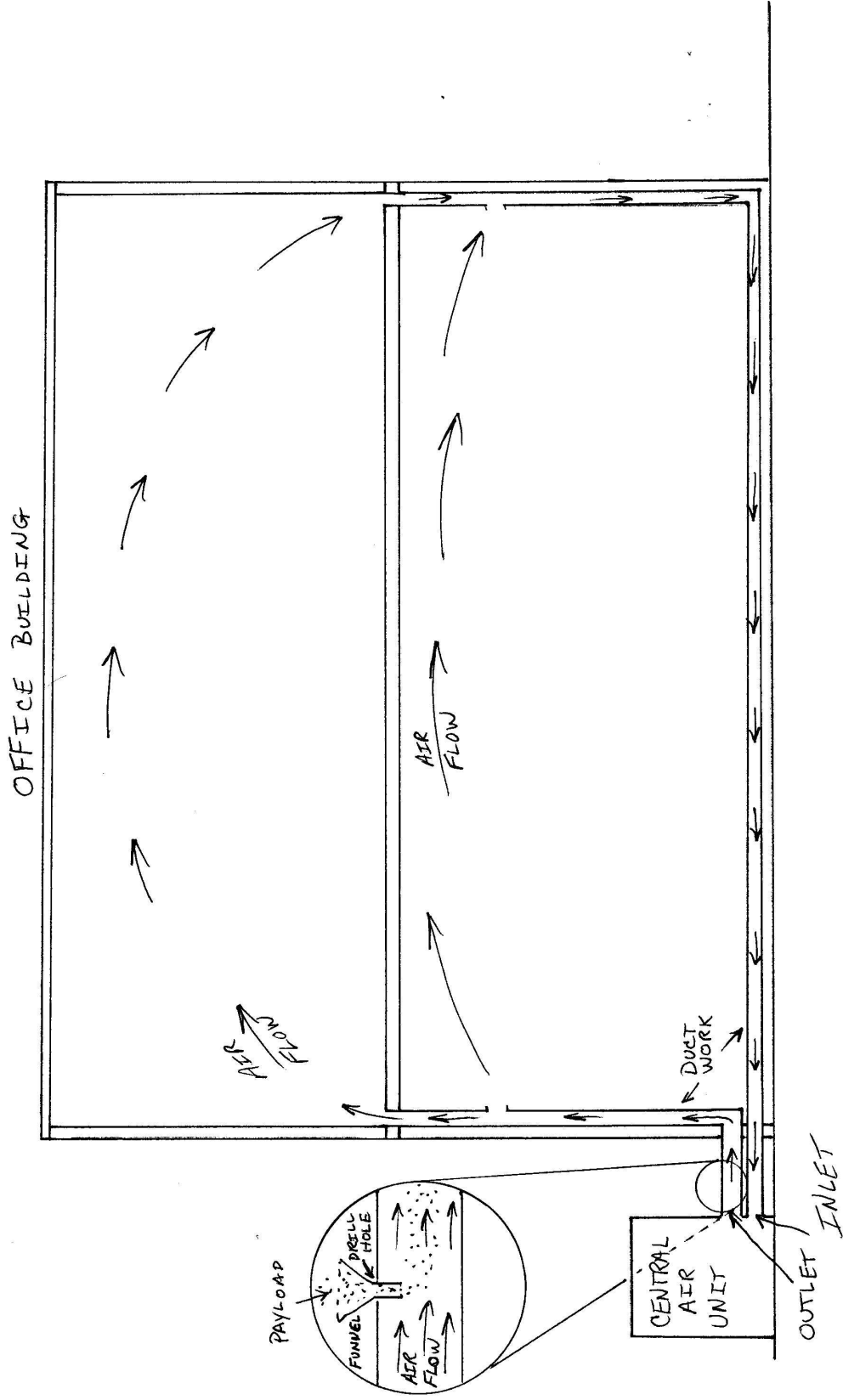

Environmental System Attack

ENVIRONMENTAL SYSTEM ATTACK

An efficient way of attacking enemy personnel is illustrated here. The central air conditioning unit is the key to this delivery system. The outlet leading into the building delivers the gas vapor payload and distributes the payload throughout the building. Smoke grenades are a great way to clear a building with a minimal amount of effort with maximum distribution throughout the structure....

Warning: *This Book/Sketchs are presented solely for Academic Purposes Only. The manufacture of Explosive and firearms or weapons is illegal without proper authority and licenses from BATF. Do not use this book to construct the described parts without licenses or authorization from this agency.*

The procedures in this book are dangerous and can result in either physical injury or death. The author assume no responsibility for use or misuse of the information contained herein.

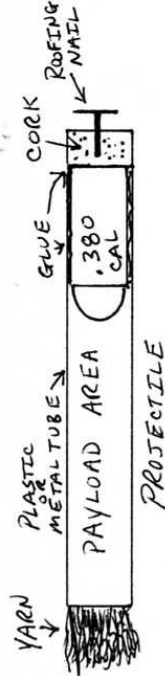
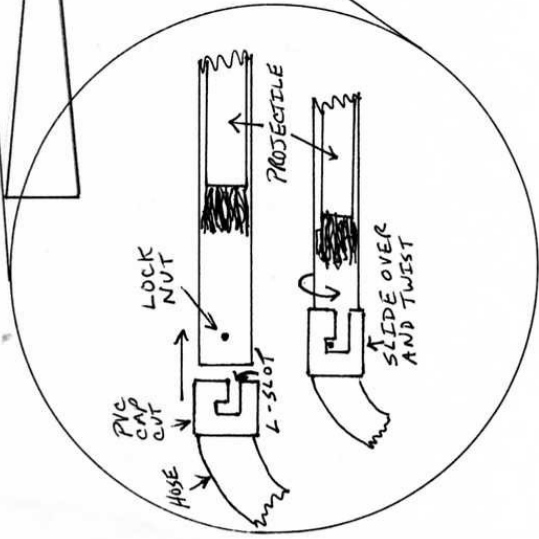
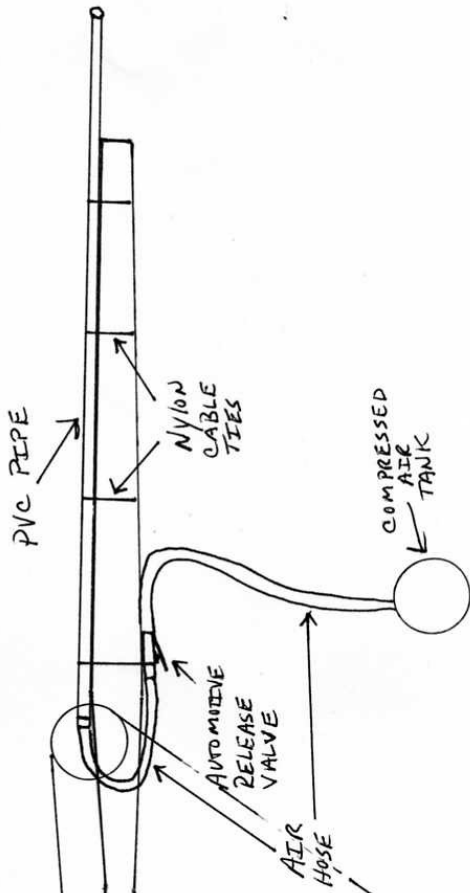
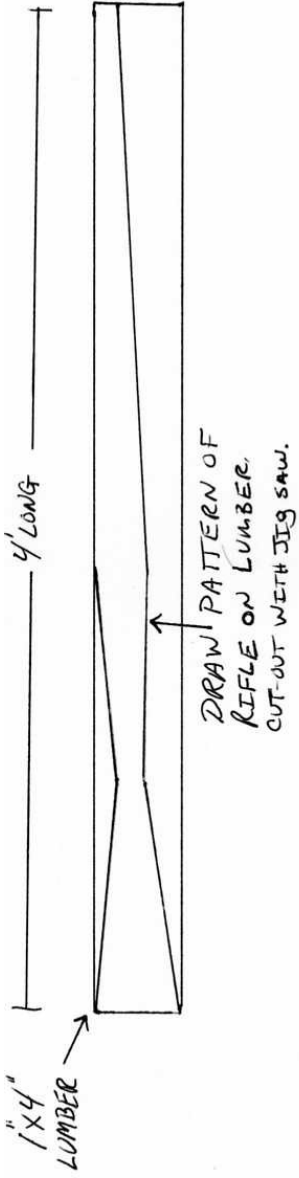

DART AIR RIFLE

Dart Air Rifle

The weapon illustrated here is of the simplest to make. The stock is made from a piece of 1" by 4" lumber cut-out with a jigsaw. The barrel is a small PVC pipe attached to the stock using nylon cable ties. A PVC cap is attached to a air compressor hose secured so it will not come off. Using a Dremel Rotary tool, cut-out a "L" slot in the cap. This will serve as the means of attaching the air hose to the barrel. Lock nuts are made into the barrel. These knots serve as the means of attachment of the PVC cap to the barrel. I have used flathead screws drilled from the inside out with success.

Be sure that the projectile can slide past the screw heads with ease. The projectile is made of PVC tubing. Cardboard tubing could also work. The back of the projectile is plugged and yarn is glued to the plug to form a seal when compressed air is flooded into the barrel. A small caliber center-fired bullet glued in backwards serves as a detonation device. A cork or other material is used to hold the firing pin of which is a roofing nail. A round ball-bearing cemented on top of the primer could also work...

Warning: *This Book/Sketchs are presented solely for Academic Purposes Only. The manufacture of Explosive and firearms or weapons is illegal without proper authority and licenses from BATF. Do not use this book to construct the described parts without licenses or authorization from this agency.*

The procedures in this book are dangerous and can result in either physical injury or death. The author assume no responsibility for use or misuse of the information contained herein.

STOP & LOOK!

THIS SHEET CONTAINS IMPORTANT INFORMATION ABOUT YOUR SAFETYCAN™ UNIT!

IMPORTANT INFORMATION ABOUT YOUR ORDER:

If you ordered more than one unit of this product, each unit will be shipped in a **separate** package to assure that it arrives in perfect condition.



IMPORTANT INFORMATION ON HOW TO USE YOUR SAFETYCAN™!

SafetyCan™ operates differently than ordinary can openers! Please read the "Instructions For Use" on the box or insert, and the information below before using your SafetyCan™.

NOTE: To release the SafetyCan™ from the lid, turn the knob counter-clockwise one quarter of a turn.

Rifle Propelled Soda Can Launcher





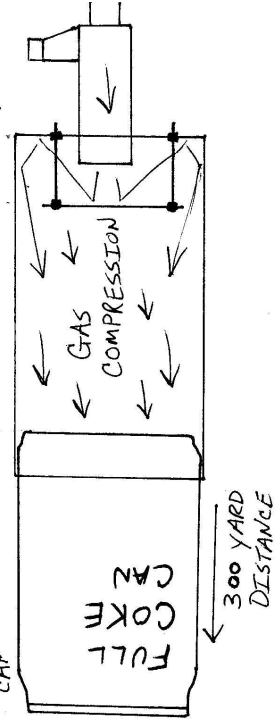
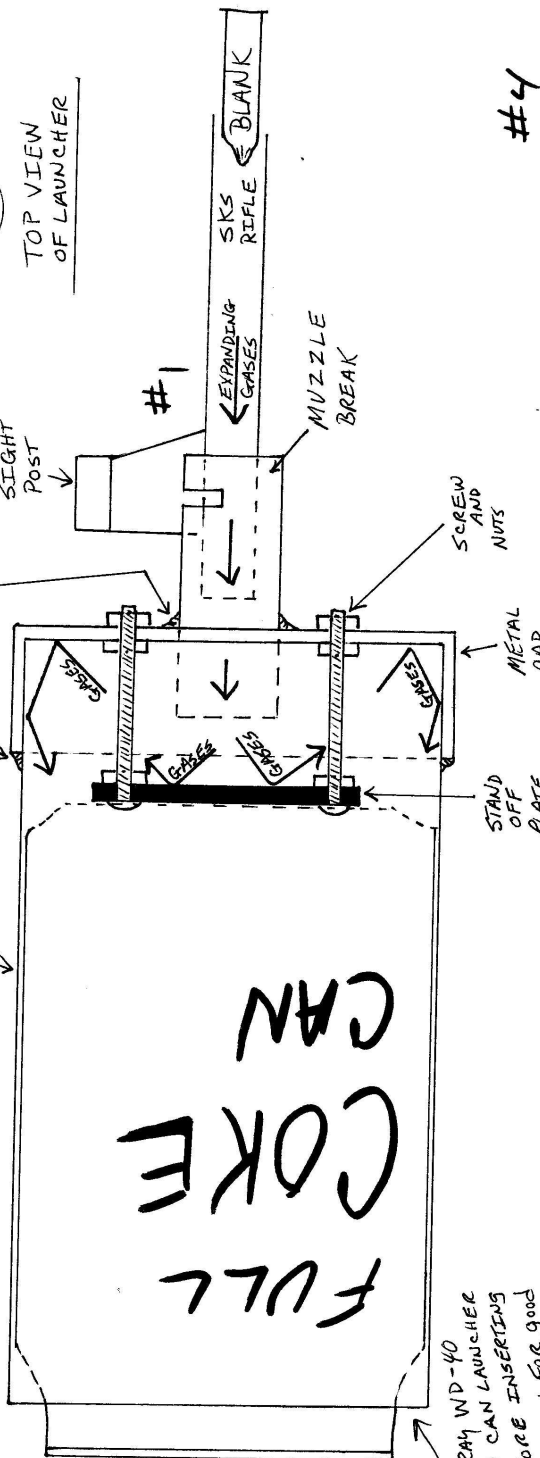
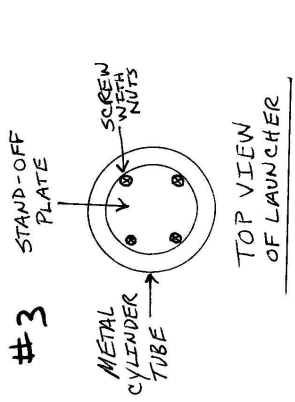
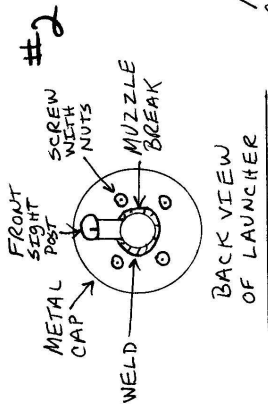

FULL COKE CAN

SPRAY WD-40 INTO CAN LAUNCHER BEFORE INSERTING SODA-CAN FOR GOOD COMPRESSION SEAL

RIFLE Propelled Soda-CAN LAUNCHER

Rifle Propelled Soda Can Launcher

The launcher illustrated here is designed around a SKS rifle using a muzzle break as a means of attachment and detachment for the rifle.

Figure #1 shows the metal cylinder tube which has the same inside diameter as the outside diameter of a full soda can. A metal cap has had a hole drilled through to allow the muzzle break through and welded into place. A standoff plate [to keep at a distance] is installed by welding legs to the inside of the cap [see figure #2 and #3].

A blank SKS 7.62mm by 39mm cartridge is used as a propellant. When the blank round is fired, the expanding gas hits the stand-off plate which prevents the gases from ripping into the projectile, bounces off the stand-off plate into the space provided by the plate and the cap [this all takes place in 1/100 of a second]. Pressure is built-up and propelles the soda can some 300 yards [see figure #4]!

Note: WD-40 is sprayed into the launcher prior to inserting the soda can to ensure a good pressure seal.

Warning: This Book/Sketchs are presented solely for Academic Purposes Only. The manufacture of Explosive and firearms or weapons is illegal without proper authority and licenses from BATF. Do not use this book to construct the described parts without licenses or authorization from this agency.

The procedures in this book are dangerous and can result in either physical injury or death. The author assume no responsibility for use or misuse of the information contained herein.

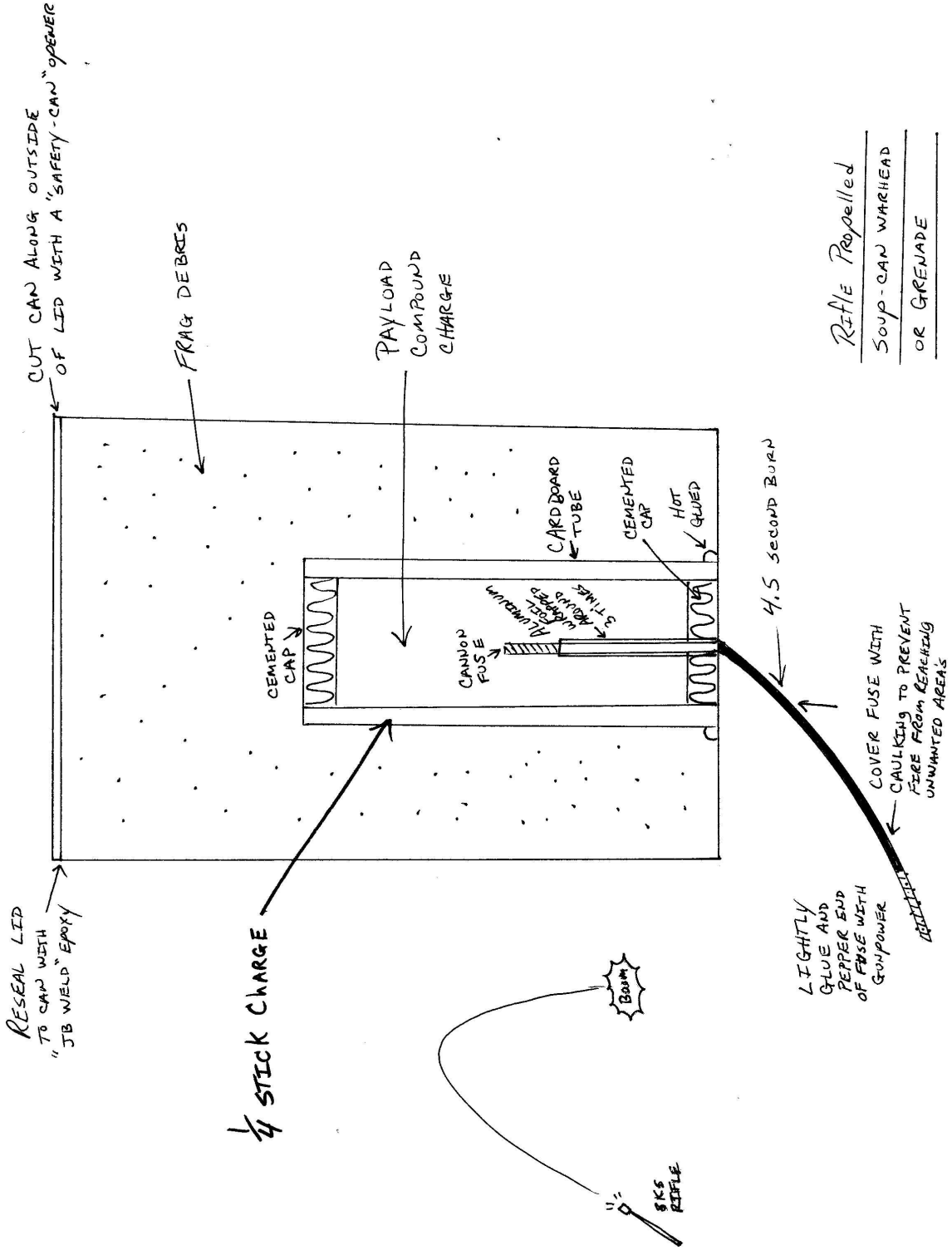

Rifle Propelled Soup Can Warhead

The warhead illustrated here can be used with the Rifle Propelled Soda Can Launcher to produce a effective weapons system. The warheads can be used as standard hand thrown grenades. First secure a tin can with the same diameter of a soda can. Open the can with a safety can lid opener [illustrated above]. Dump or eat contents, and wash out can. Drill a small hole the same size as your cannon fuse. Insert you ¼ stick charge [covered in this book] that has had epoxy applied to its edge liberally to ensure both a good fit to the inside of the can and so that no sparks can seep into the tin can based on the payload chosen. Frag is used inside and the lid is reattached to the top using liberal amounts of JB Weld [auto mechanic weld] to secure snug to the top.

Warning: *This Book/Sketchs are presented solely for Academic Purposes Only. The manufacture of Explosive and firearms or weapons is illegal without proper authority and licenses from BATF. Do not use this book to construct the described parts without licenses or authorization from this agency.*

The procedures in this book are dangerous and can result in either physical injury or death. The author assume no responsibility for use or misuse of the information contained herein.

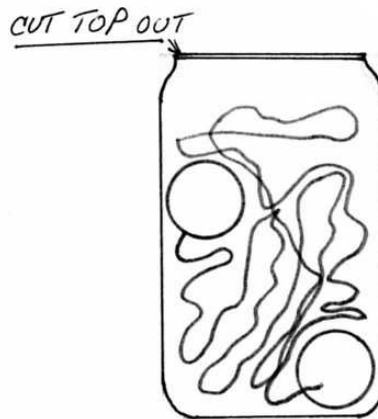
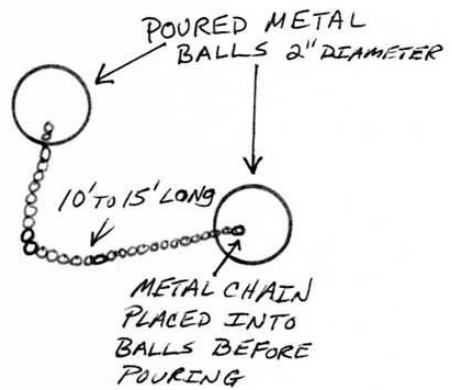
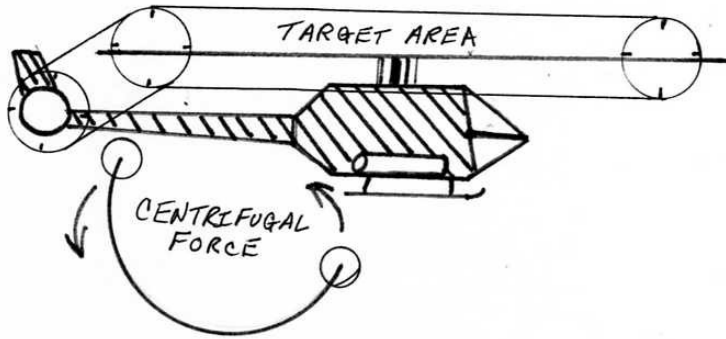

RIFLE PROPELLED
SODA-CAN BOLA
ANTI-CHOPPER ROUND

Rifle Propelled Soda Can Launcher Bola Round

The warhead illustrated here uses the soda can launcher with a hollow pepsi can or soup can containing two metal or cement balls with a 10' to 15' chain connecting the two balls together. Once fired at the target, the balls exit the can, and centrifical force takes over which cause the balls to spin between themselves. If a low flying helo happens to come within firing range, the weight and entanglement caused by the bola round will bring the helo crashing to the ground...

Warning: *This Book/Sketchs are presented solely for Academic Purposes Only. The manufacture of Explosive and firearms or weapons is illegal without proper authority and licenses from BATF. Do not use this book to construct the described parts without licenses or authorization from this agency.*

The procedures in this book are dangerous and can result in either physical injury or death. The author assume no responsibility for use or misuse of the information contained herein.

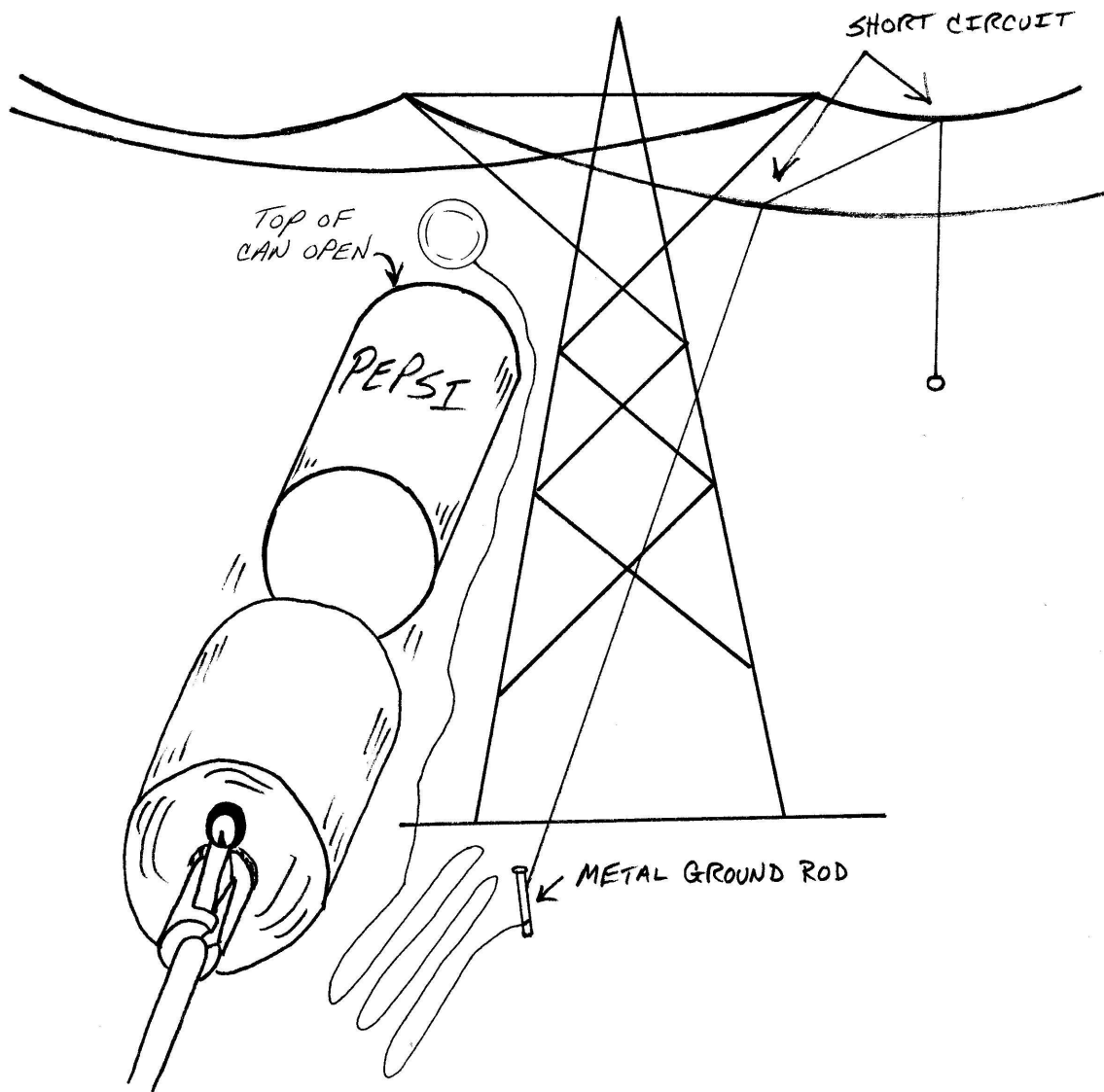

RIFLE PROPELLED
SODA-CAN LIGHTING
ROD ROUND

Rifle Propelled Soda Can Launcher Lighting Rod Round

The warhead illustrated here uses the soda can launcher with a hollow tin can containing one metal or cement ball with an electrically conductive wire which is shot over utility power lines to short-out grids. A ground rod is nailed into the ground underneath the lines.

Warning: This Book/Sketchs are presented solely for Academic Purposes Only. The manufacture of Explosive and firearms or weapons is illegal without proper authority

and licenses from BATF. Do not use this book to construct the described parts without licenses or authorization from this agency.

The procedures in this book are dangerous and can result in either physical injury or death. The author assume no responsibility for use or misuse of the information contained herein.

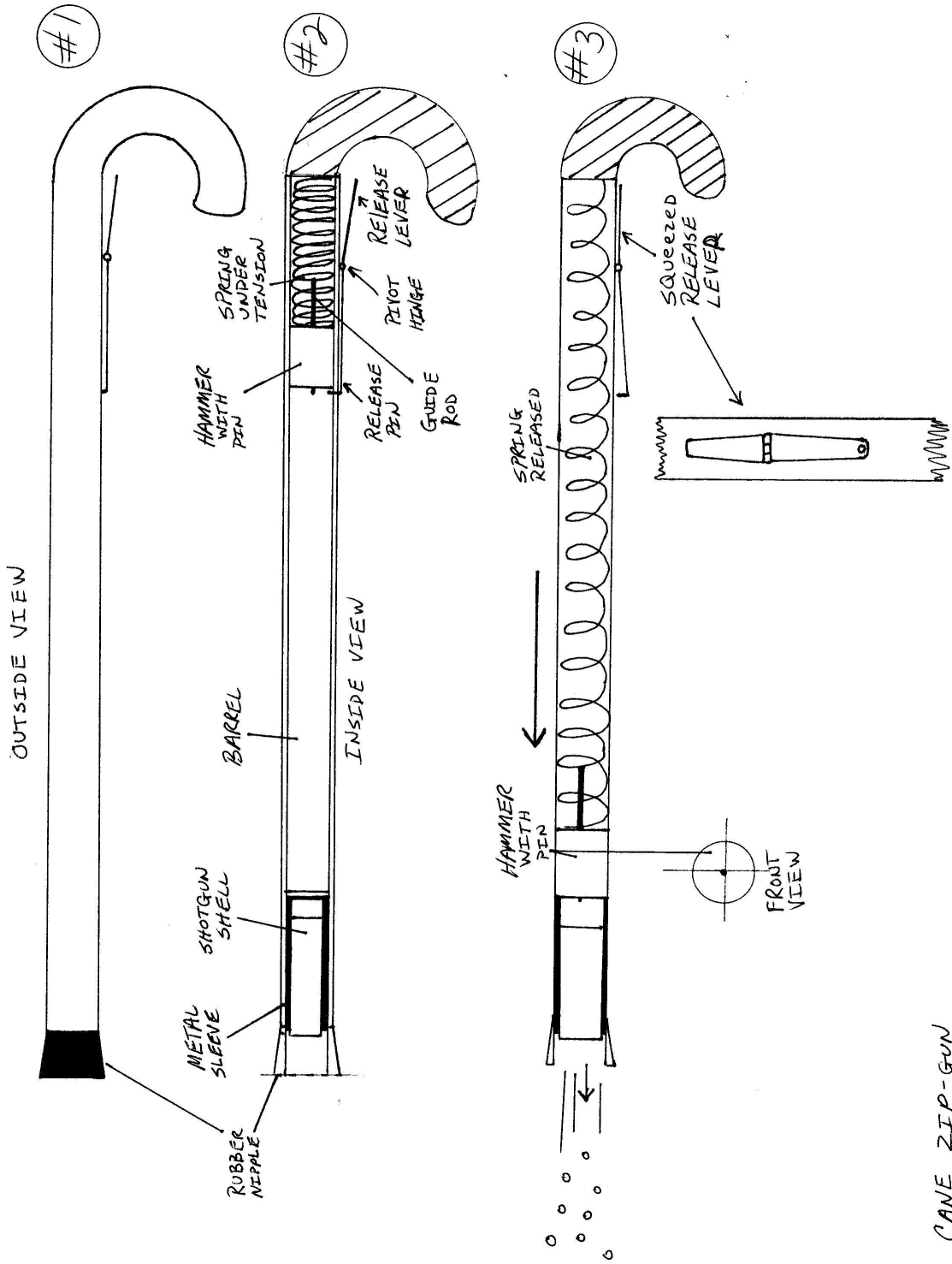

Cane Zip-Gun

CANE ZIP-GUN

The covert weapon illustrated here is designed to look like a ordinary walking stick. The trigger is the only part seen from the outside as shown in figure #1.

The internal parts are displayed in figure #2. Starting at the rubber nipple of the cane. It does not matter if the rubber nipple has a hole pathway for the lead shot. It is up to the makers discretion. This design is a one shot only then ditch the weapon [never to be found again].

The shotgun shell is held in place by a metal or wooden or cardboard sleeve. This keeps the primer on center in the barrel and prevents it's movement.

The hammer with a fixed firing pin is simple to construct. The hammer is nothing more than a round metal cylinder with the same outside diameter as the inside diameter of the barrel. A hole is drilled dead center with either a nail or screw welded in place for the firing pin. File the pin down to a sharp point. A guide rod is installed on the opposite side of the hammer.

A strong spring [salvaged from a old automatic shotgun] is used under tension by the trigger release level which has a holding pin on one side to hold the hammer in place til the operator squeeze the trigger to release the spring which propels the hammer forward to strike the shot shell in figure #3.

Warning: *This Book/Sketchs are presented solely for Academic Purposes Only. The manufacture of Explosive and firearms or weapons is illegal without proper authority and licenses from BATF. Do not use this book to construct the described parts without licenses or authorization from this agency.*

The procedures in this book are dangerous and can result in either physical injury or death. The author assume no responsibility for use or misuse of the information contained herein.

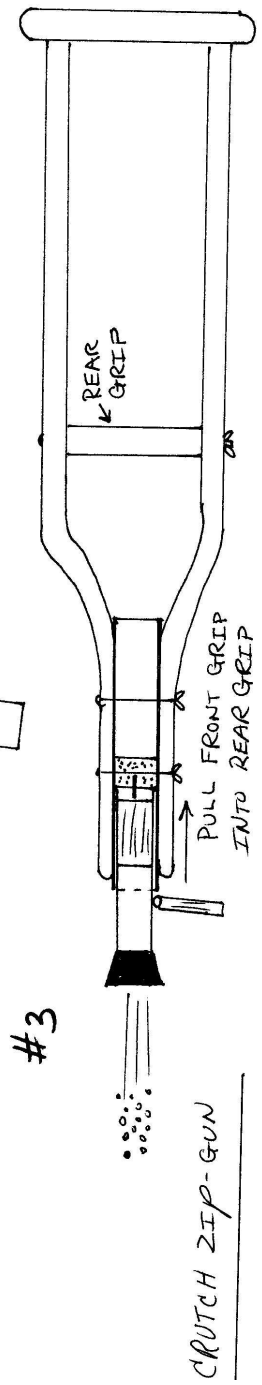
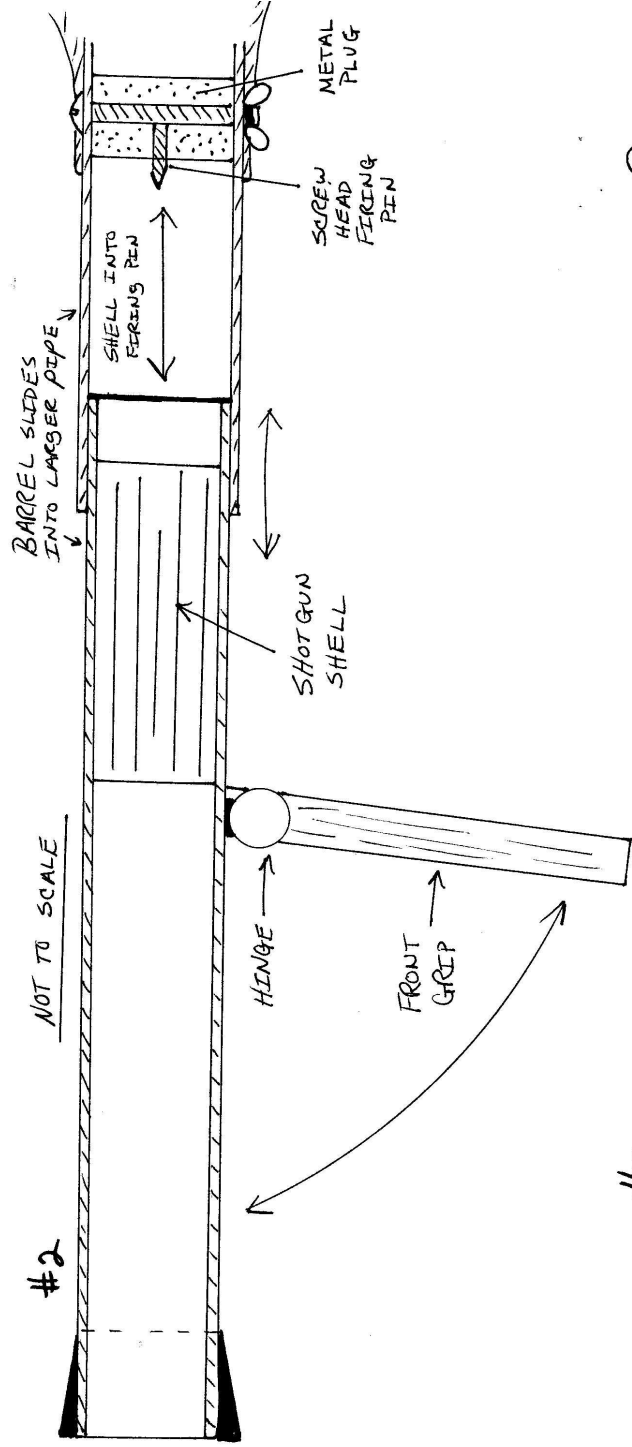
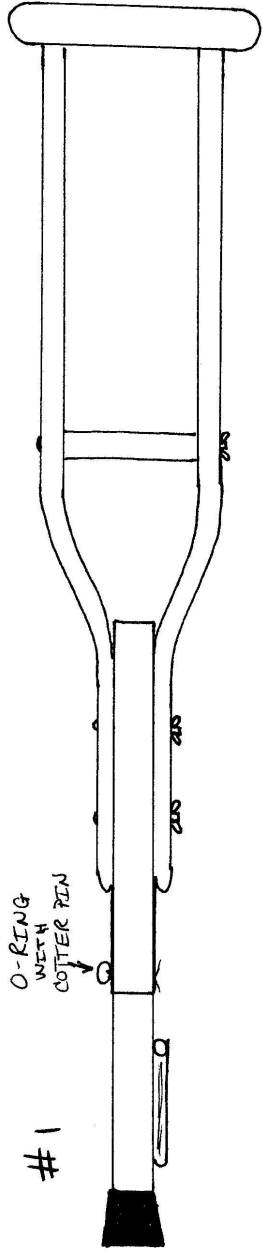

Crutch Zip-Gun

When I first heard of this weapon...it was used by a individual at a VA Hospital. He was going to a review board meeting over his benefits and was being harassed by one of the board members and denied benefits. The hospital had a very elaborate security system already in place with metal detectors at the doorways. This individual still managed to go through this security system, into the review meeting and pump "00" buckshot into the gentleman chest setting a mere 20 feet away. The moral of the story is if you shit on people...expect to get shit back on you!

The exterior view in figure #1 shows the front grip folded down and the cotter pin with o-ring to prevent the barrel from moving while walking on them. If painted the same color as the crutch, it would be hard to notice.

Figure #2 shows a internal view of the crutch. With the front grip folded out and the cotter pin removed, it functions as a single shot pump action shotgun. By pulling the front grip towards the shooter very hard, slamming the shot shell against a fixed metal plug with a screw head firing pin which will discharge the weapon [figure #3]. This is a single shot weapon only.

Warning: *This Book/Sketchs are presented solely for Academic Purposes Only. The manufacture of Explosive and firearms or weapons is illegal without proper authority and licenses from BATF. Do not use this book to construct the described parts without licenses or authorization from this agency.*

The procedures in this book are dangerous and can result in either physical injury or death. The author assume no responsibility for use or misuse of the information contained herein.

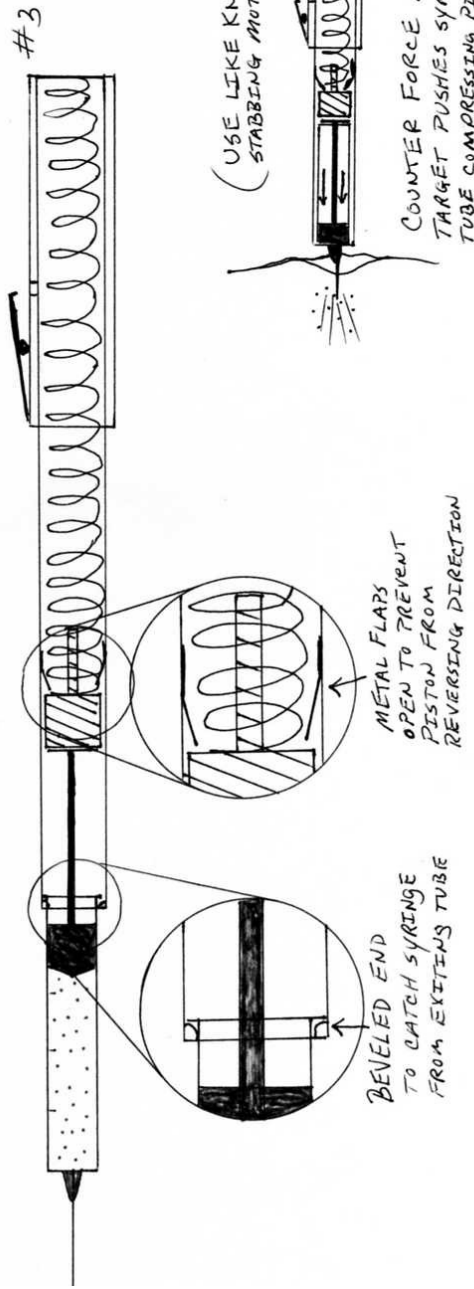
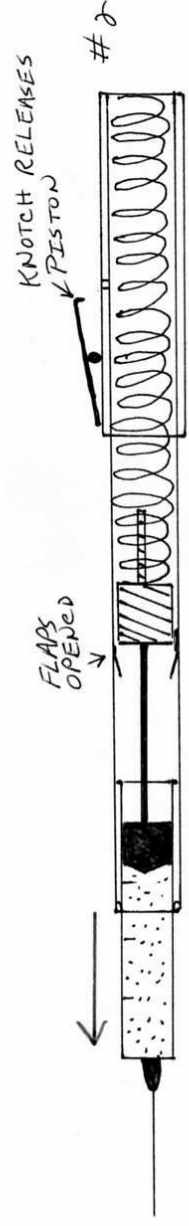
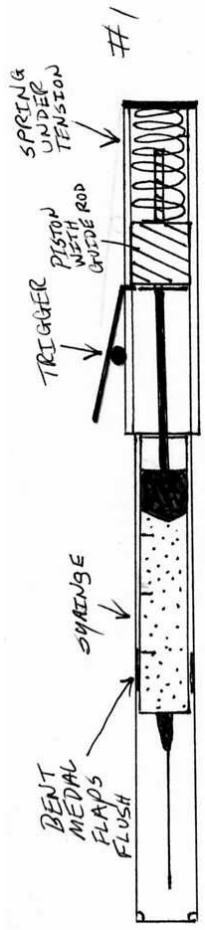

SWITCH BLADE FANG

Switch Blade Fang

The illustrated weapon shown is used just like a knife. The counter force applied from the target pushes the syringe back into the housing tube which compresses on the plunger to release it's payload into the target.

Figure #1 shows the weapon ready for release. Figure #2 shows the trigger pushed which releases the piston under tension. Figure #3 shows bevels on the inside of the tube to catch the syringe from exiting completely.

Small metal flaps on the inside prevent the piston from re-entering the weapon once passed this stage. The wooden pen and pencil making kits sold by woodcraft distributors would make an attractive exterior tube for one of these devices.

Warning: *This Book/Sketchs are presented solely for Academic Purposes Only. The manufacture of Explosive and firearms or weapons is illegal without proper authority and licenses from BATF. Do not use this book to construct the described parts without licenses or authorization from this agency.*

The procedures in this book are dangerous and can result in either physical injury or death. The author assume no responsibility for use or misuse of the information contained herein.

#1

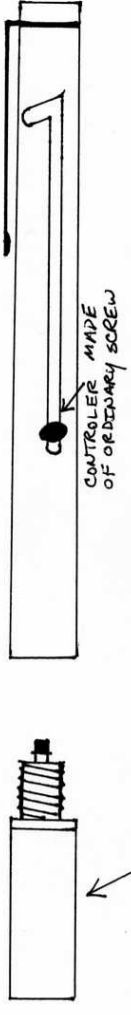

#2

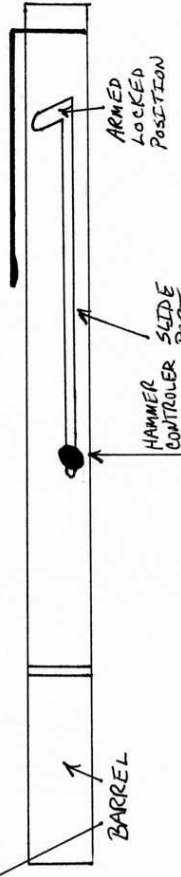

#3

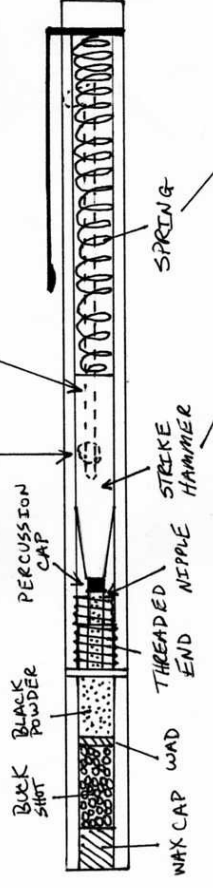

#4

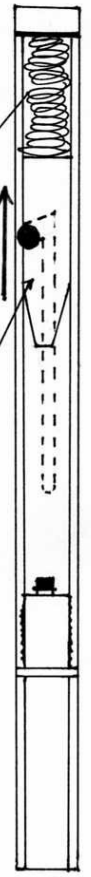

#5

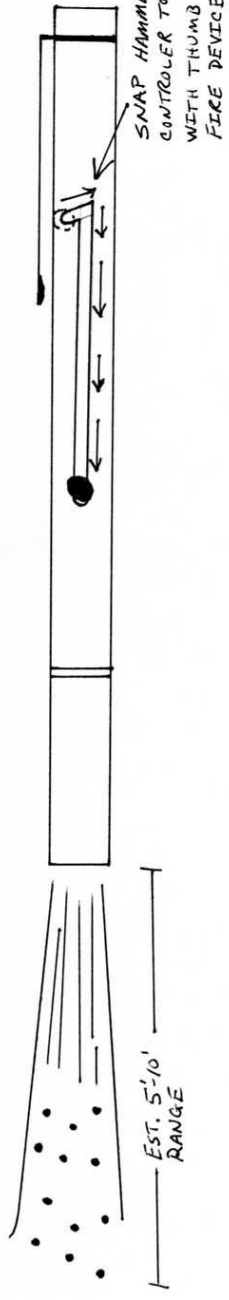

SNAP HAMMER
CONTROLLER TO SIDE
WITH THUMB TO
FIKE DEVICE

PEN GUN

Pen Gun

This device illustrated uses a screw-on barrel and can be re-used. It fires buckshot similiar to the muzzle loaded black powder weapon.

Figure #1 shows the barrel separate from the pen device. The hammer striker is moved by the controller knob made from a simple screw tapped into the hammer striker and moves up and down the slide port to control the arming and firing of the weapon as shown in figures #2 and #5.

An internal view of the pen is shown in figure #3. A soft wax cap seals the barrel just like a black powder muzzle loader to keep the shot in and the wet enviroment out. Next, is your buckshot, wad, black powder, channel to cap and percussion cap.

Always set the hammer in the lock armed position when attaching the barrel to prevent premature discharge. Next, comes the striker hammer which will not exit the pen due to the slide port and controller contacting each other. And last, the spring held under tension by the hammer.

Special Note:

Warning! Only 3 types of people carry such a device and if you are found with a Zip-Pen-Gun in your possession by Law Enforcement...you will be considered as one of the 3 listed:

1. Terrorist
2. Government "SPOOK" Agent
3. Freelance Mercenary

Warning: *This Book/Sketchs are presented solely for Academic Purposes Only. The manufacture of Explosive and firearms or weapons is illegal without proper authority and licenses from BATF. Do not use this book to construct the described parts without licenses or authorization from this agency.*

The procedures in this book are dangerous and can result in either physical injury or death. The author assume no responsibility for use or misuse of the information contained herein.

OUTSIDE VIEW

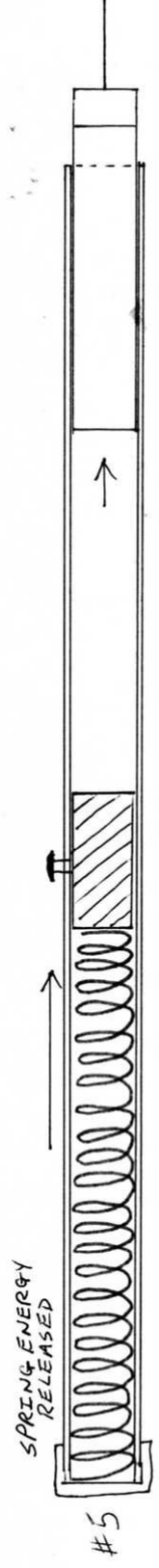
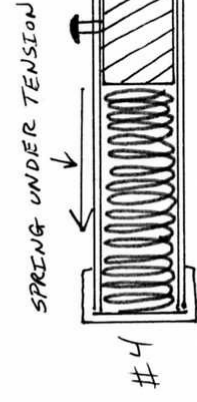
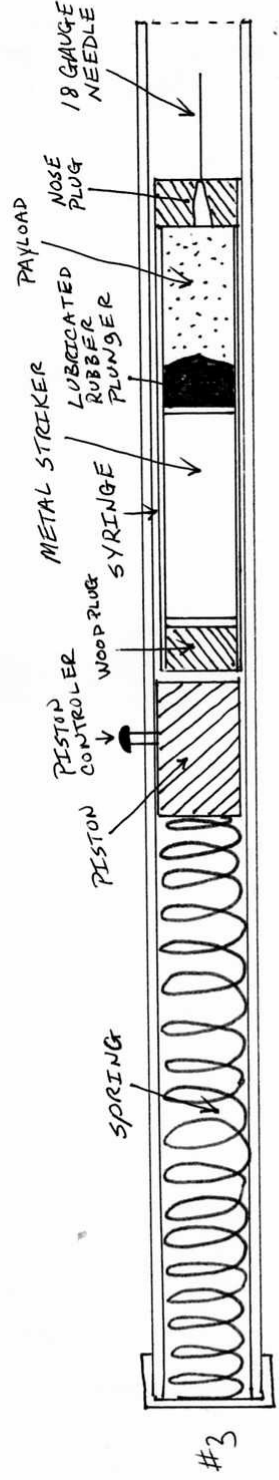
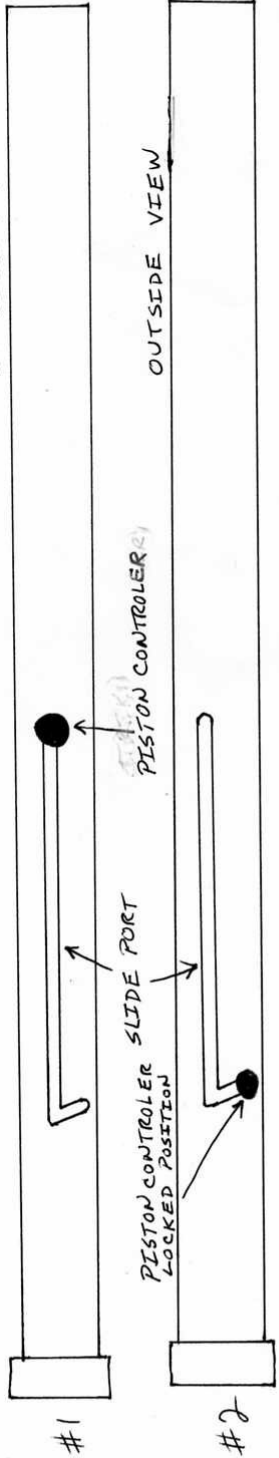

PISTON GUN

Piston Gun

Figure #1 and #2 illustrates the outer view of this weapon. The piston is controlled by a knob [ordinary screw] tapped into the piston. When the piston controller is pulled down the slide port to its locking position, it is armed.

Figure #3 shows a cut-away view of the projectile. A farm animal syringe will work nice. As you can see, the plunger stem has been removed and replaced by a metal striker. This acts as a kinetic counter-force once the syringe has hit its target. The inter-syringe tube is wiped with a lubrication to ease the delivery of the payload through the kinetic counter-force action.

The nose plug has had a flat surface added. The manufactures of professional animal control darts states;

The use of heavy loads [a lot of propellant] at short ranges may cause impact damage to a thin skinned or light muscle animals. Range of the projectile is from 0-15 meters [close-up weapon] and will travel more like a golfball in flight than a bullet.

Warning: *This Book/Sketchs are presented solely for Academic Purposes Only. The manufacture of Explosive and firearms or weapons is illegal without proper authority and licenses from BATF. Do not use this book to construct the described parts without licenses or authorization from this agency.*

The procedures in this book are dangerous and can result in either physical injury or death. The author assume no responsibility for use or misuse of the information contained herein.

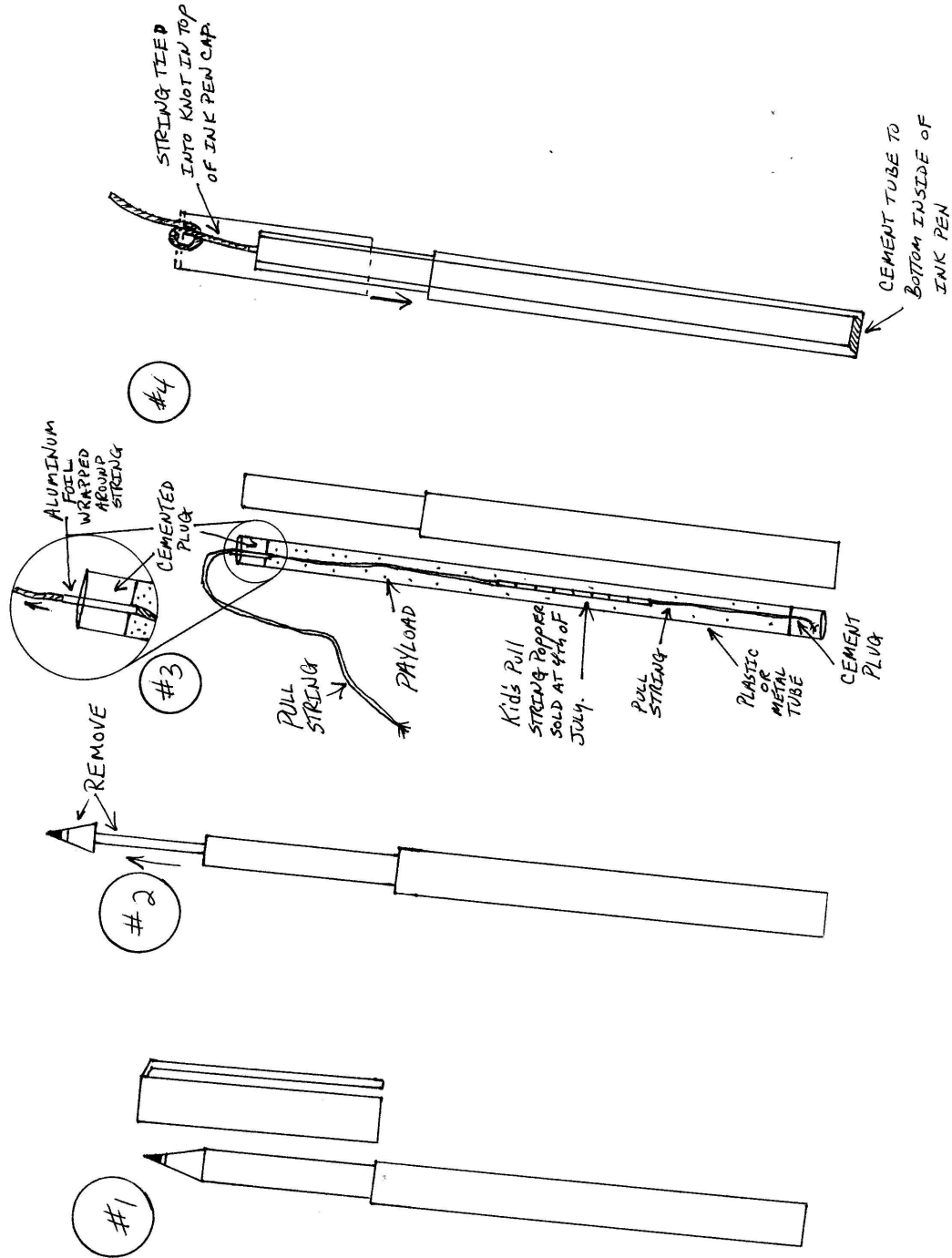

INK PEN BOOBYTRAP

#5

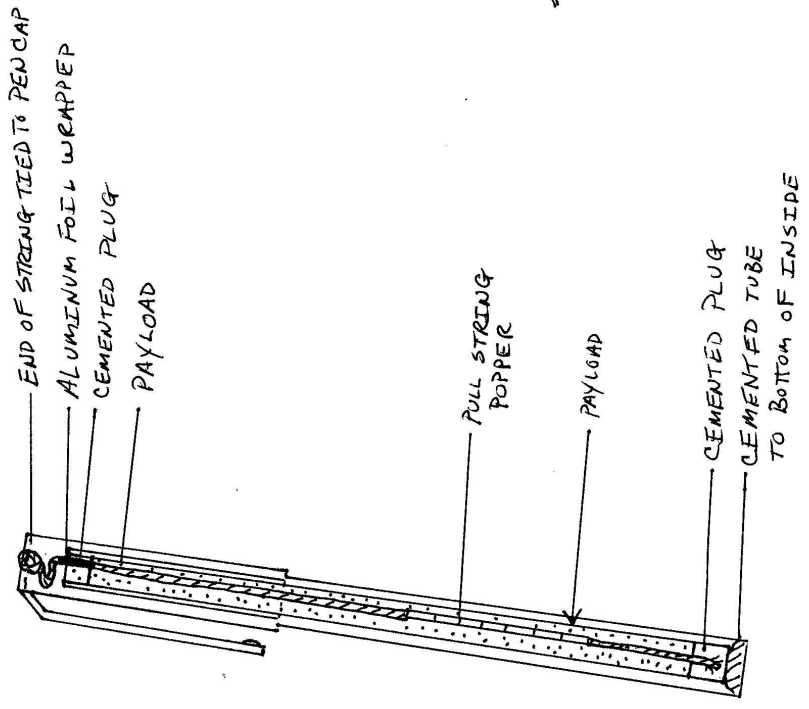

#6

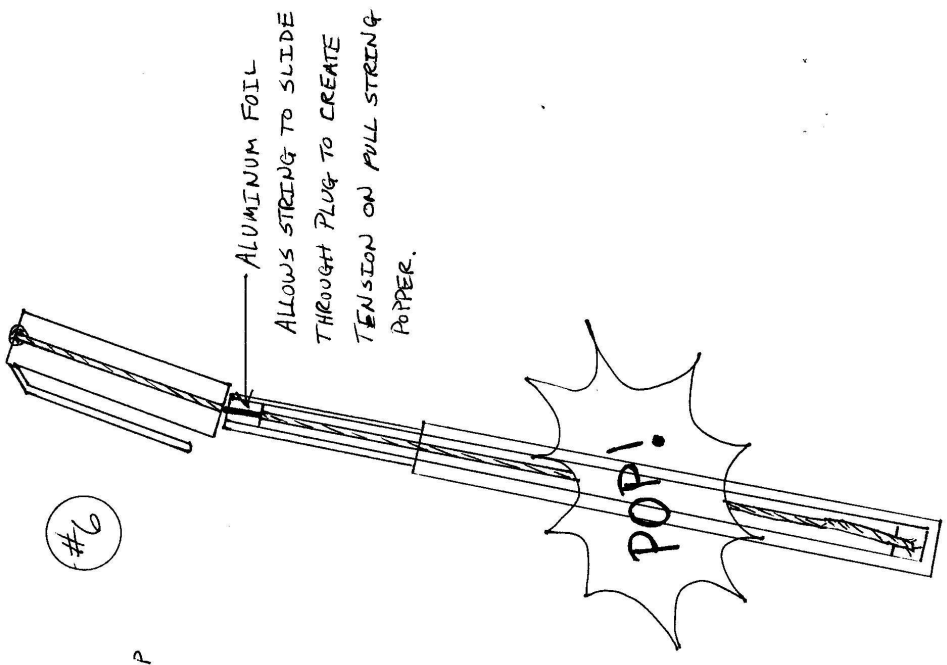

INK PEN BOOBYTRAP

(2)

Ink Pen Boobytrap

Illustrated here is a idea I got when reviewing WWII espionage devices. The principle in the simples to make and can be altered to suit your needs.

Warning: *This Book/Sketchs are presented solely for Academic Purposes Only. The manufacture of Explosive and firearms or weapons is illegal without proper authority and licenses from BATF. Do not use this book to construct the described parts without licenses or authorization from this agency.*

The procedures in this book are dangerous and can result in either physical injury or death. The author assume no responsibility for use or misuse of the information contained herein.

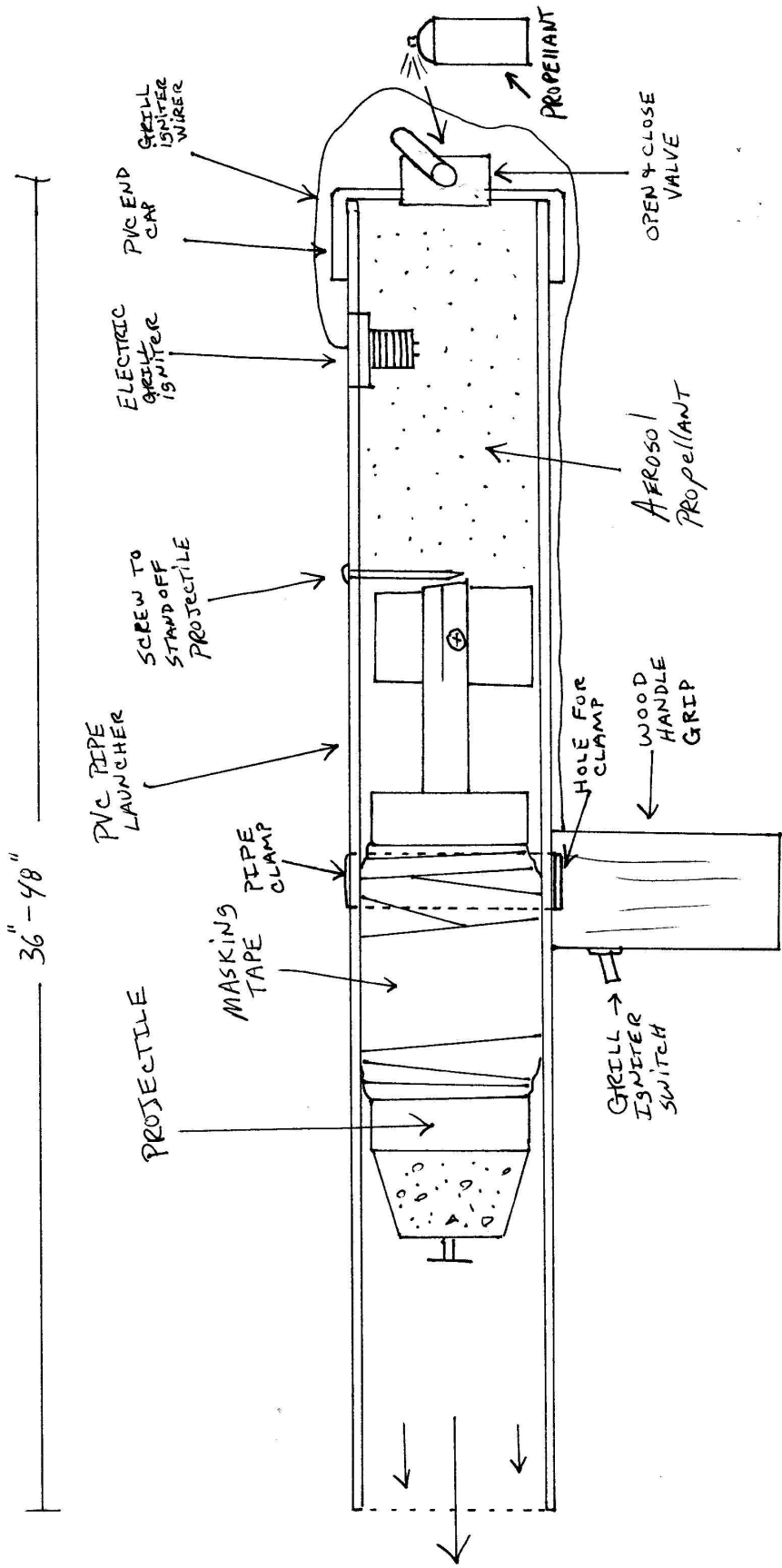

BAZOOKA LAUNCHER #1

Bazooka Launcher

The launcher illustrated here is of the simplest to construct. The launcher itself is made of PVC piping. The diameter is judged by how thick you want the warhead. Starting at the rear of the launcher is a simple open and close ball valve obtained at any hardware store. It is tapped and cemented to the PVC cap. A electric grill igniter is tapped into the pvc and cemented into place. I have found that automotive carb-starter works the best as a propellant. A screw is used as a stand-off guide to provide accurate spacing between the rear of the warhead and the combustion chamber.

A homemade grip is made from scrap wood. The grill igniter it tapped into the wooden handle. And held in place via a pipe clamp.

The warhead is also simple to make. The body is PVC pipe cut to the desired length. A bullet is cemented dead center with cork or similair material covering the end with a roofing nail acting as the firing pin.

On the other end of the PVC pipe, a round wooden dowel is also cemented dead center. Slots are cut into the dowel to allow for a thin tin fins made from scrap aluminum can to be made and held in place with a screw.

To ensure a snug fit. Wrap masking tape around the warhead body.

Warning: *This Book/Sketchs are presented solely for Academic Purposes Only. The manufacture of Explosive and firearms or weapons is illegal without proper authority and licenses from BATF. Do not use this book to construct the described parts without licenses or authorization from this agency.*

The procedures in this book are dangerous and can result in either physical injury or death. The author assume no responsibility for use or misuse of the information contained herein.

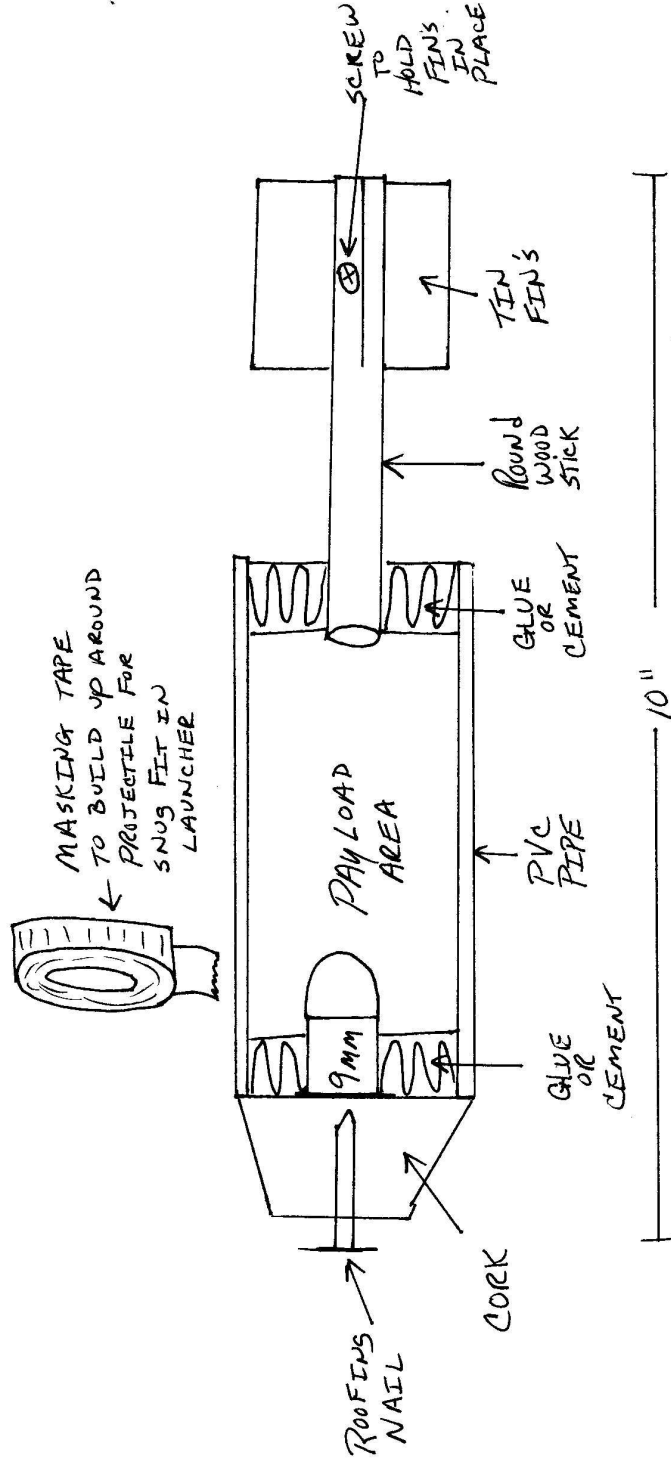
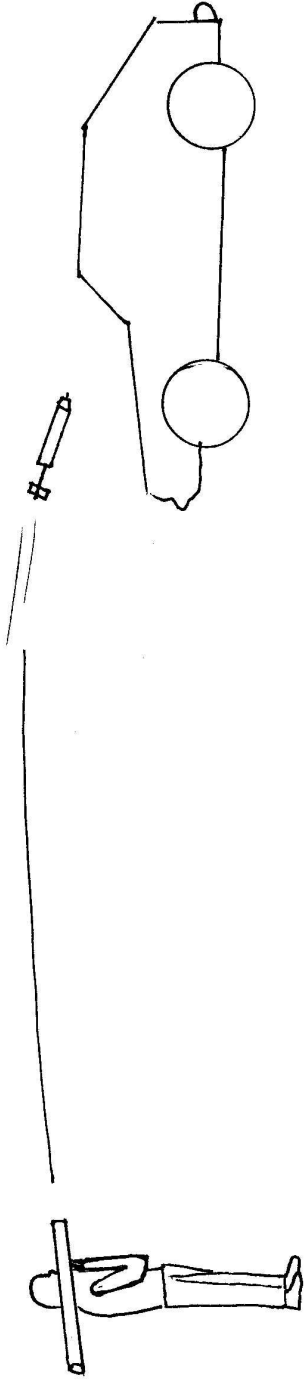

BAZOOKA PROJECTILE #2

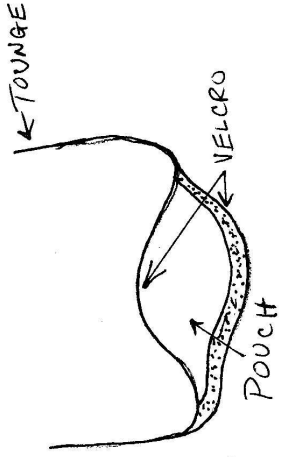

TOUNGE SEALED
BY VELCRO

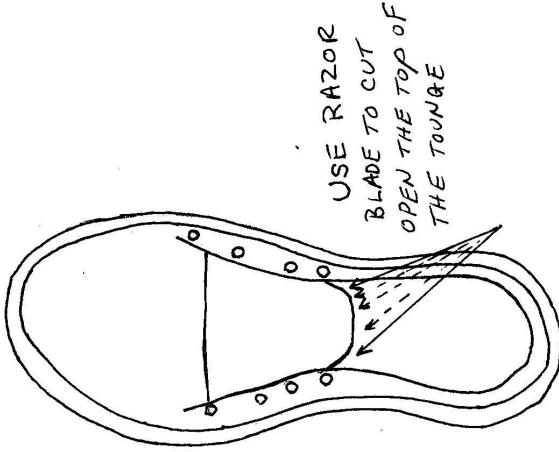
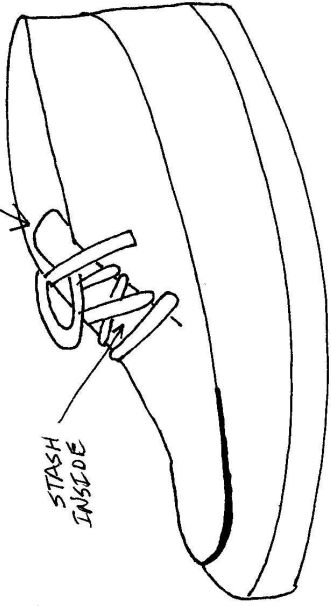

SECRET STASH HIDDEN PLACE

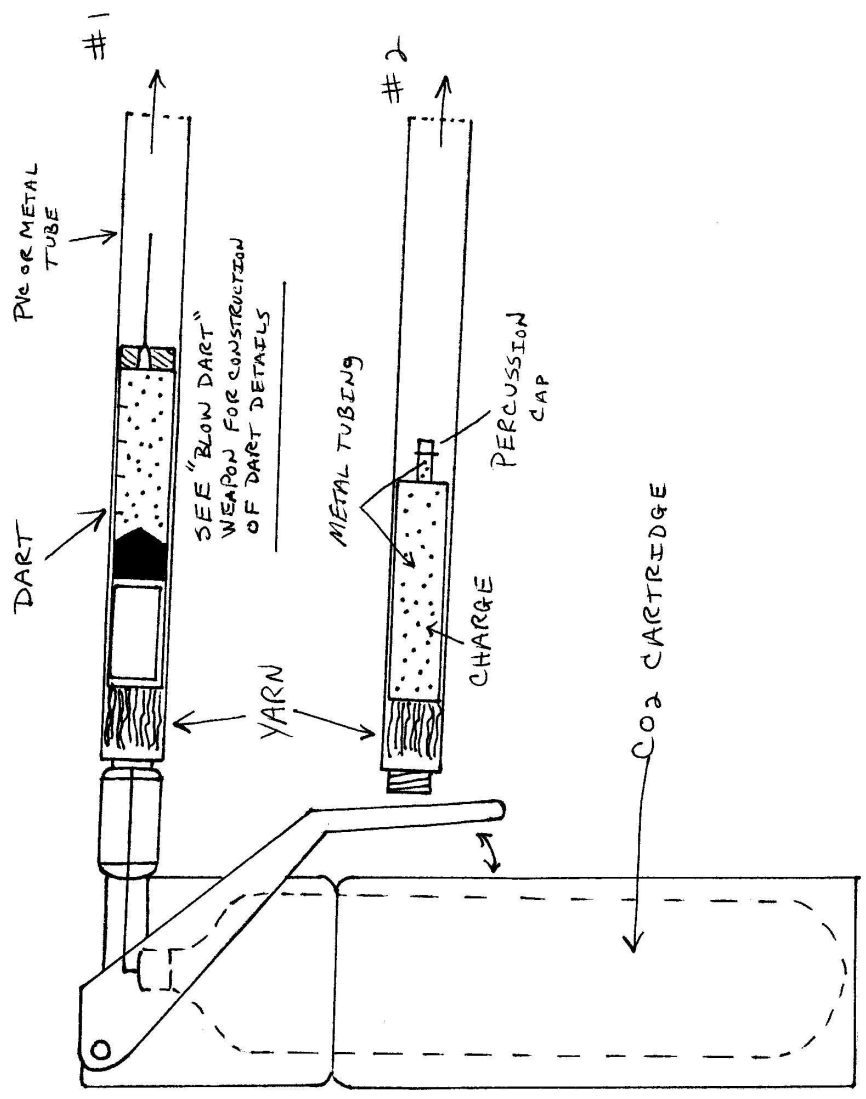

HAND HELD
 CO₂ LOAD
 DISCHARGER
 →
 USED TO CLEAR
 UNFIRED CHARGE
 FROM BLACK-POWDER
 WEAPON

CO₂ LOAD DISCHARGER WEAPON

#3

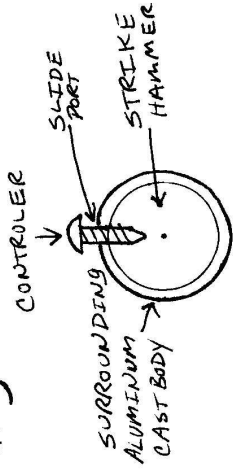

#2

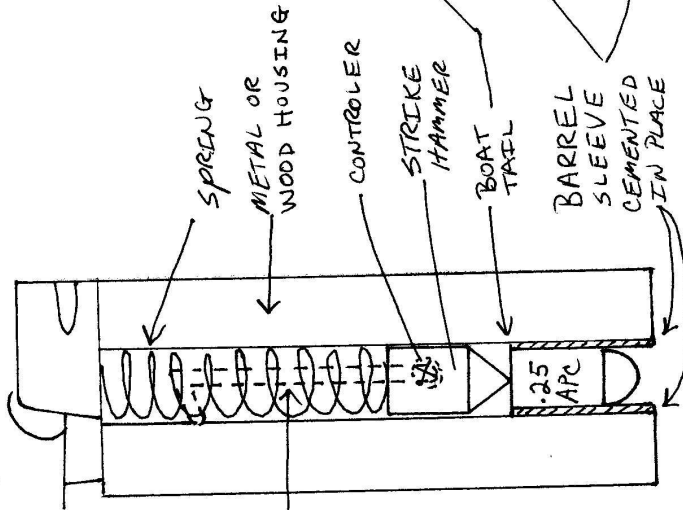

#1

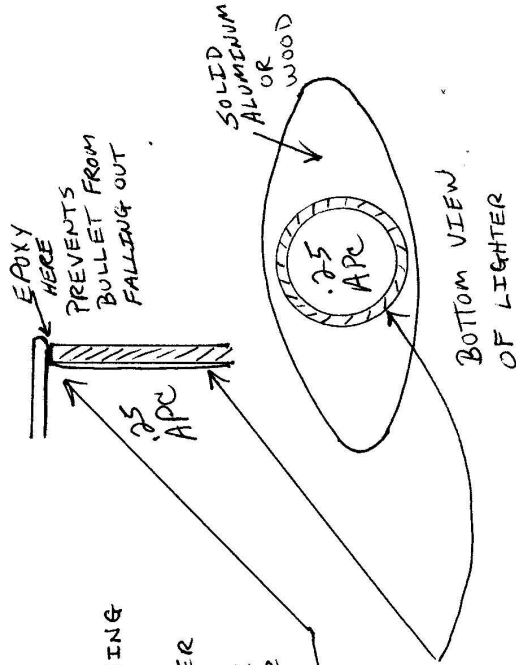
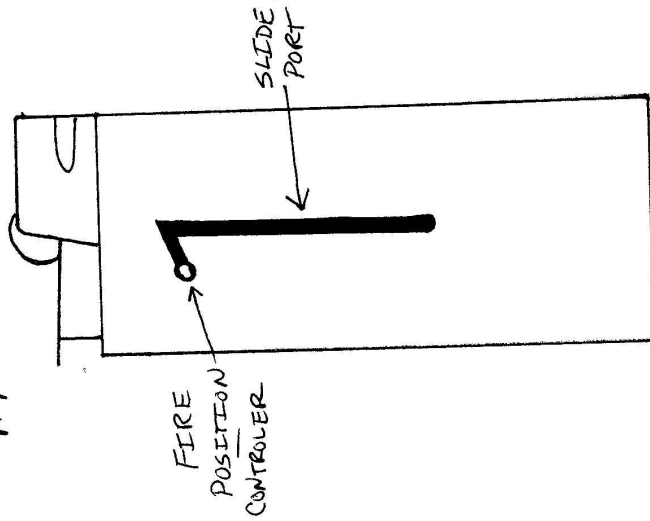

BIC LIGHTER GUN

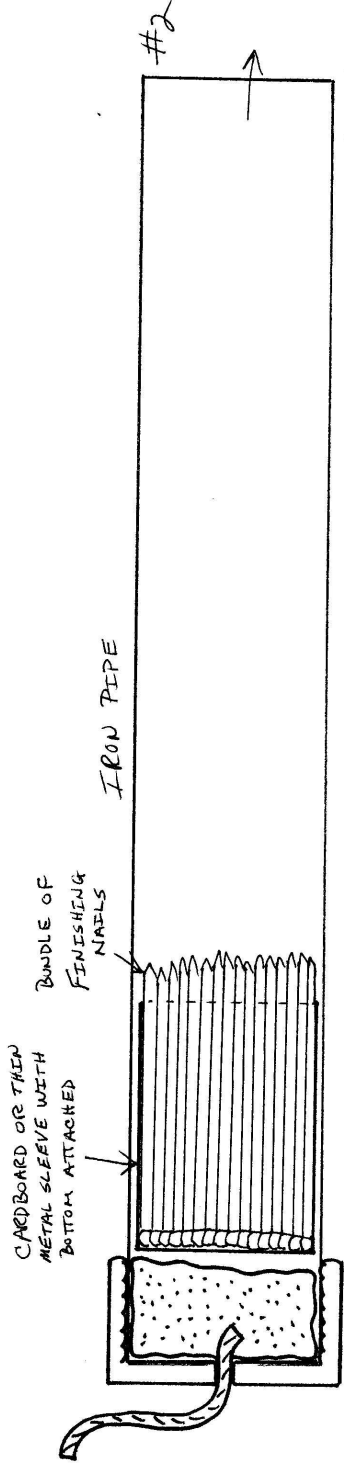
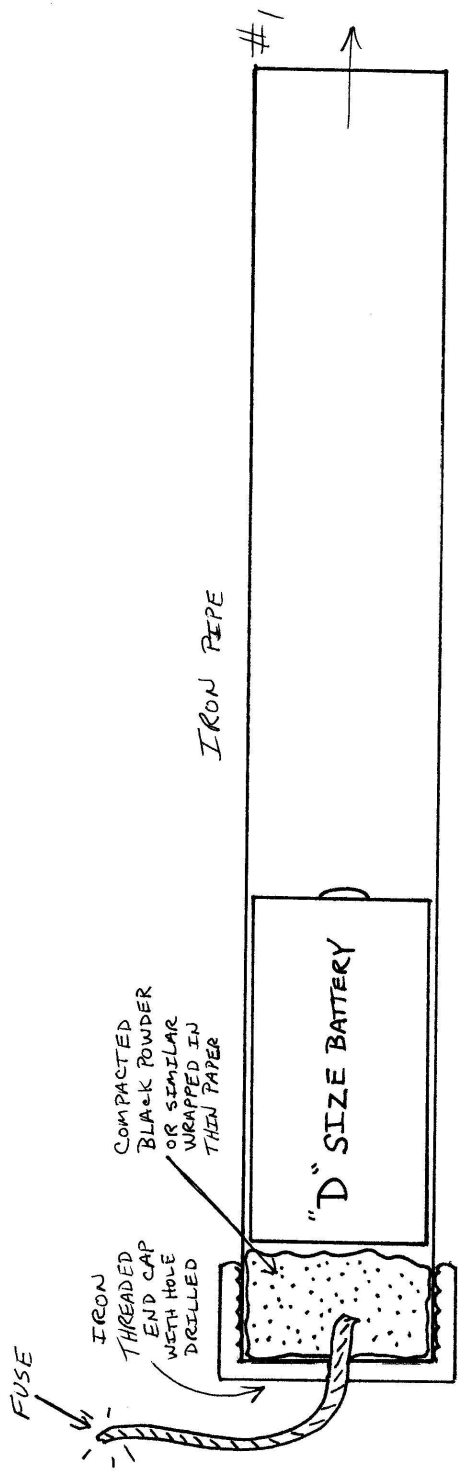

SIMPLE HOMEMADE CANNON

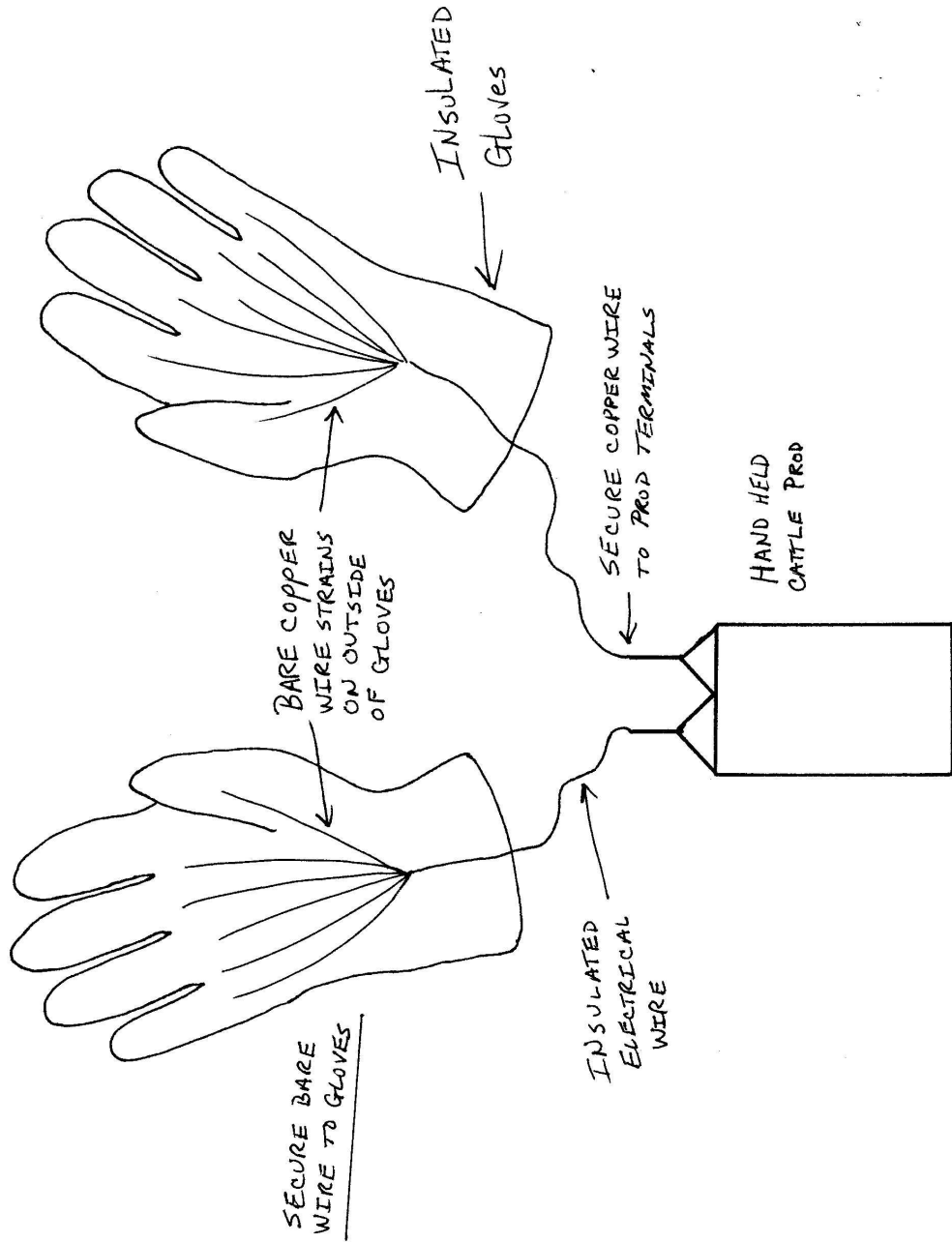

STUN GLOVES

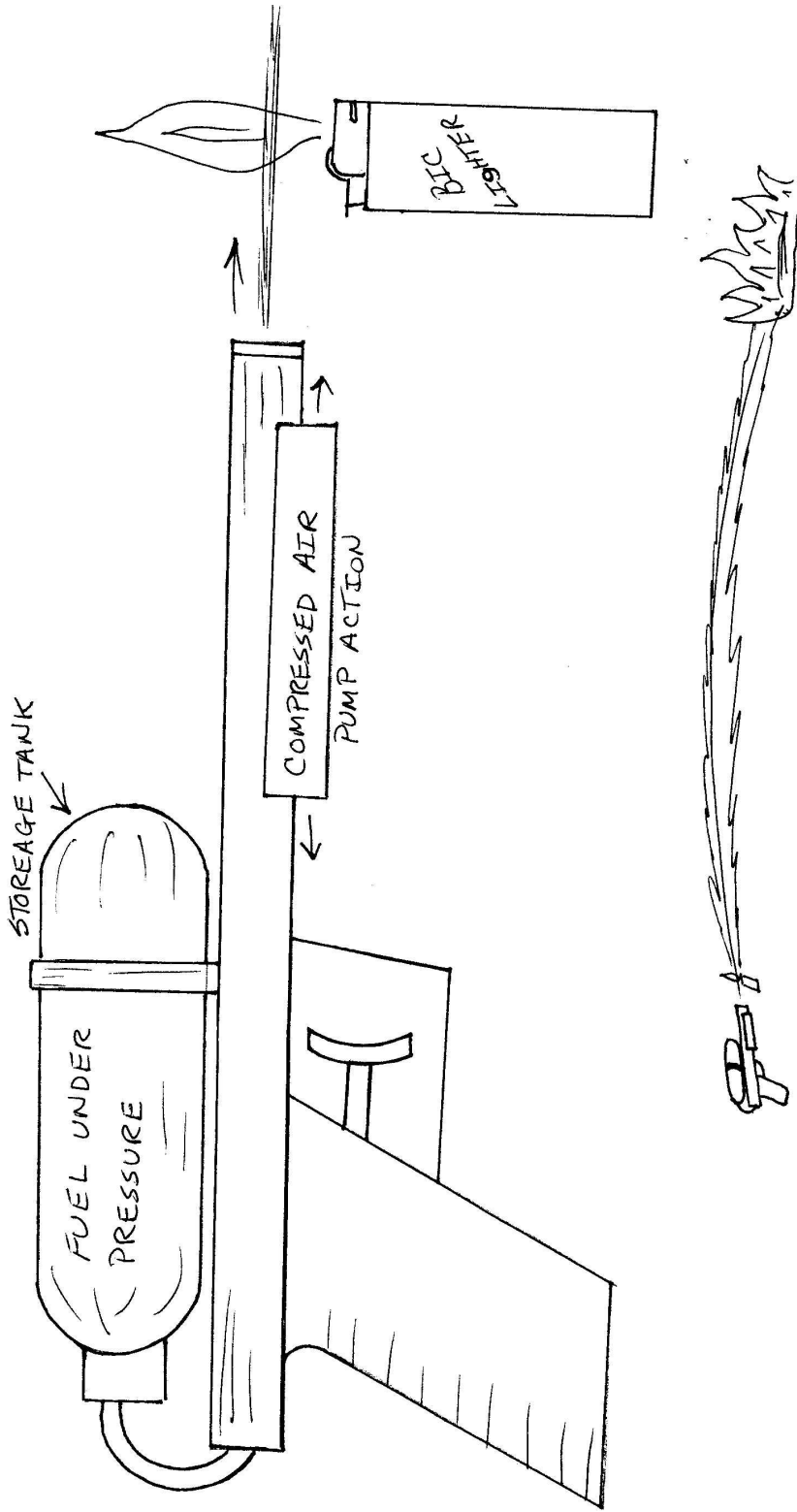

HOW A FLAME THROWER WORKS #1

CRUDE EXAMPLE

DUKES OF HAZARD ARROW

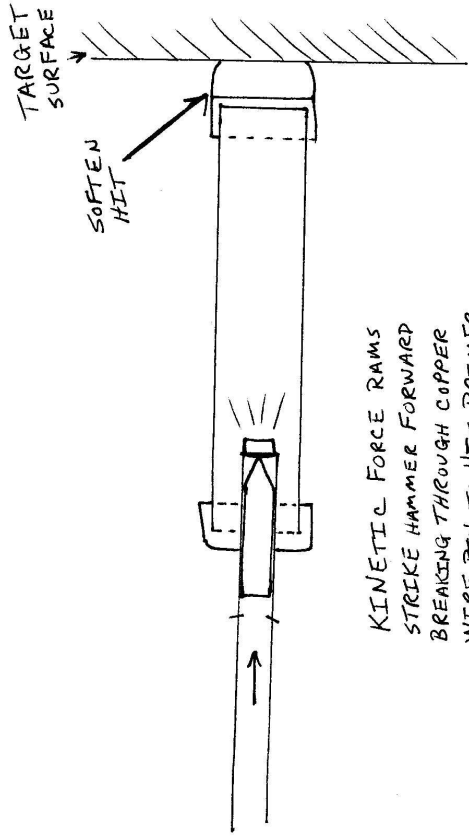
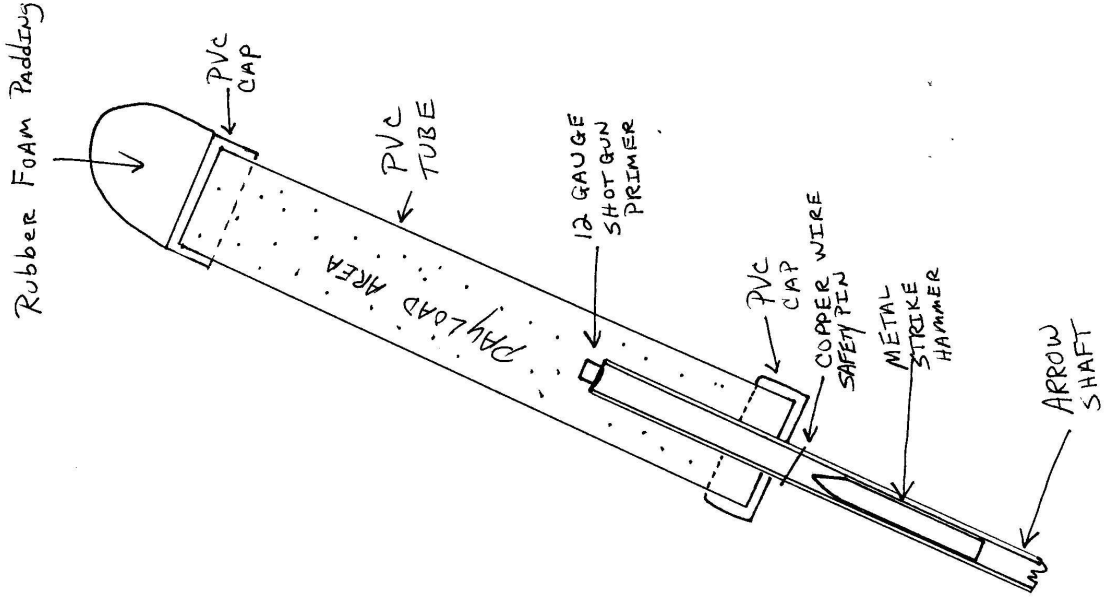
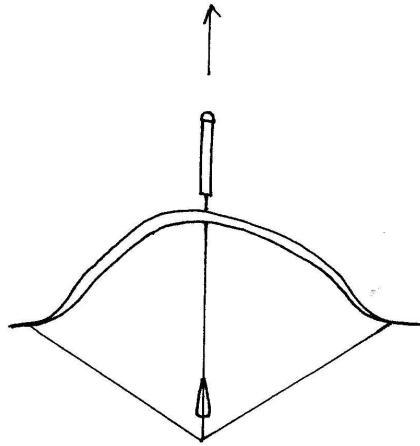

KINETIC FORCE RAMS
 STRIKE HAMMER FORWARD
 BREAKING THROUGH COPPER
 WIRE PIN TO HIT PRIMER
 FOR DETONATION.

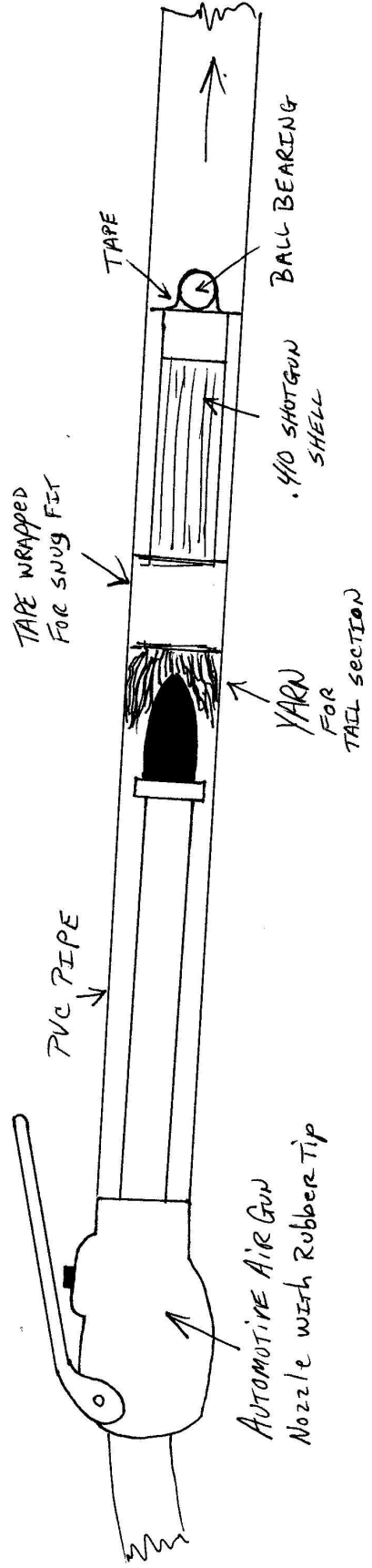

BLOW GUN WITH EXPLOSIVE WARHEAD

BLOW DART

AUTOMOTIVE AIR GUN NOZZLE
WITH RUBBER TIP

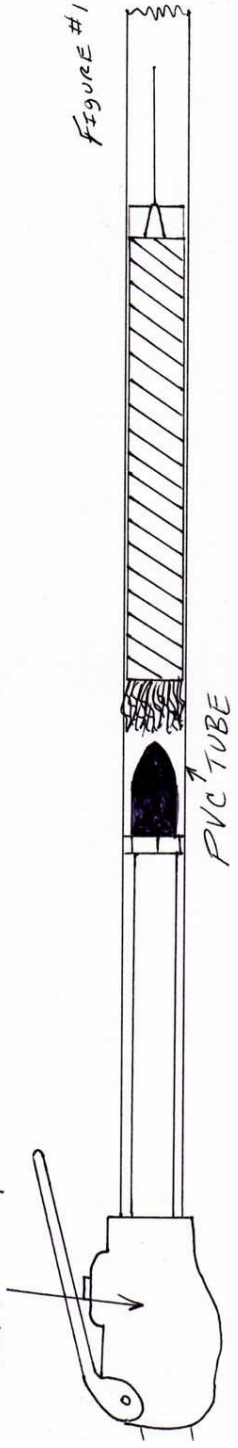

FIGURE #1

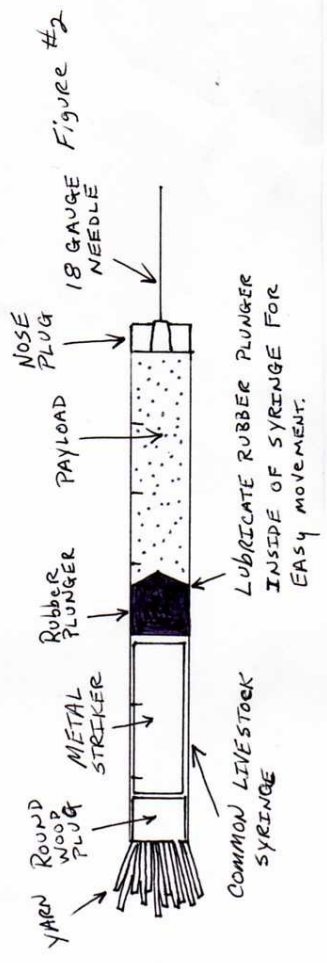
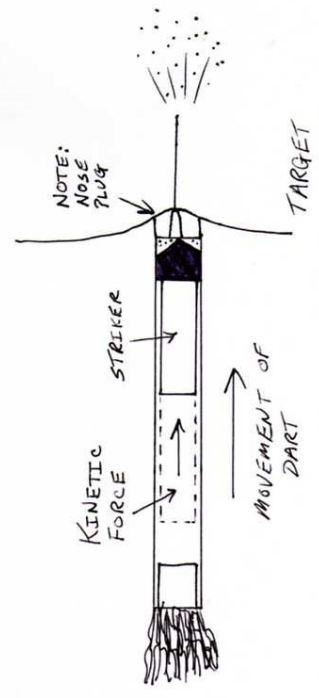

FIGURE #2



NOTE:
NOSE
PLUG

TARGET

BLOW DART

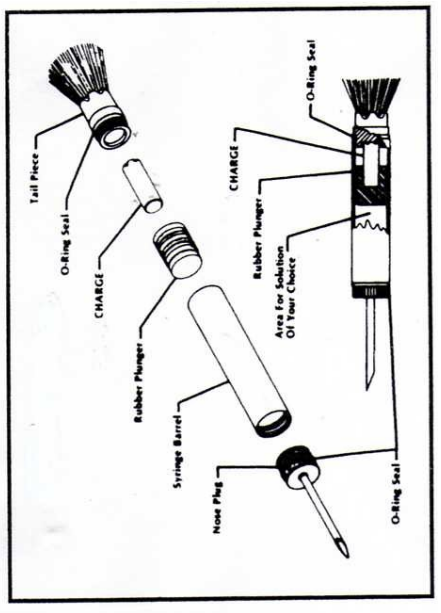

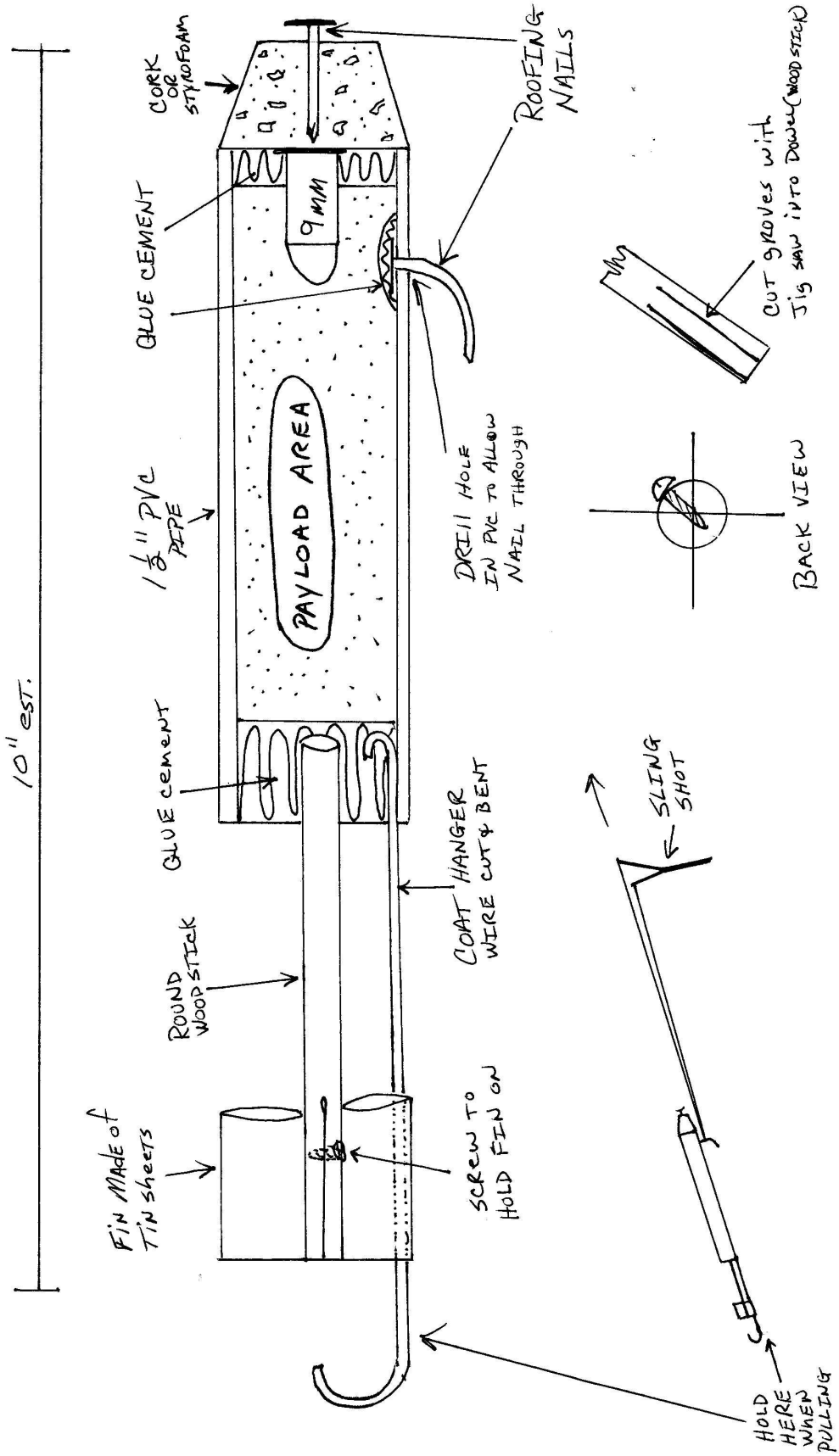

SLING SHOT MORTAR

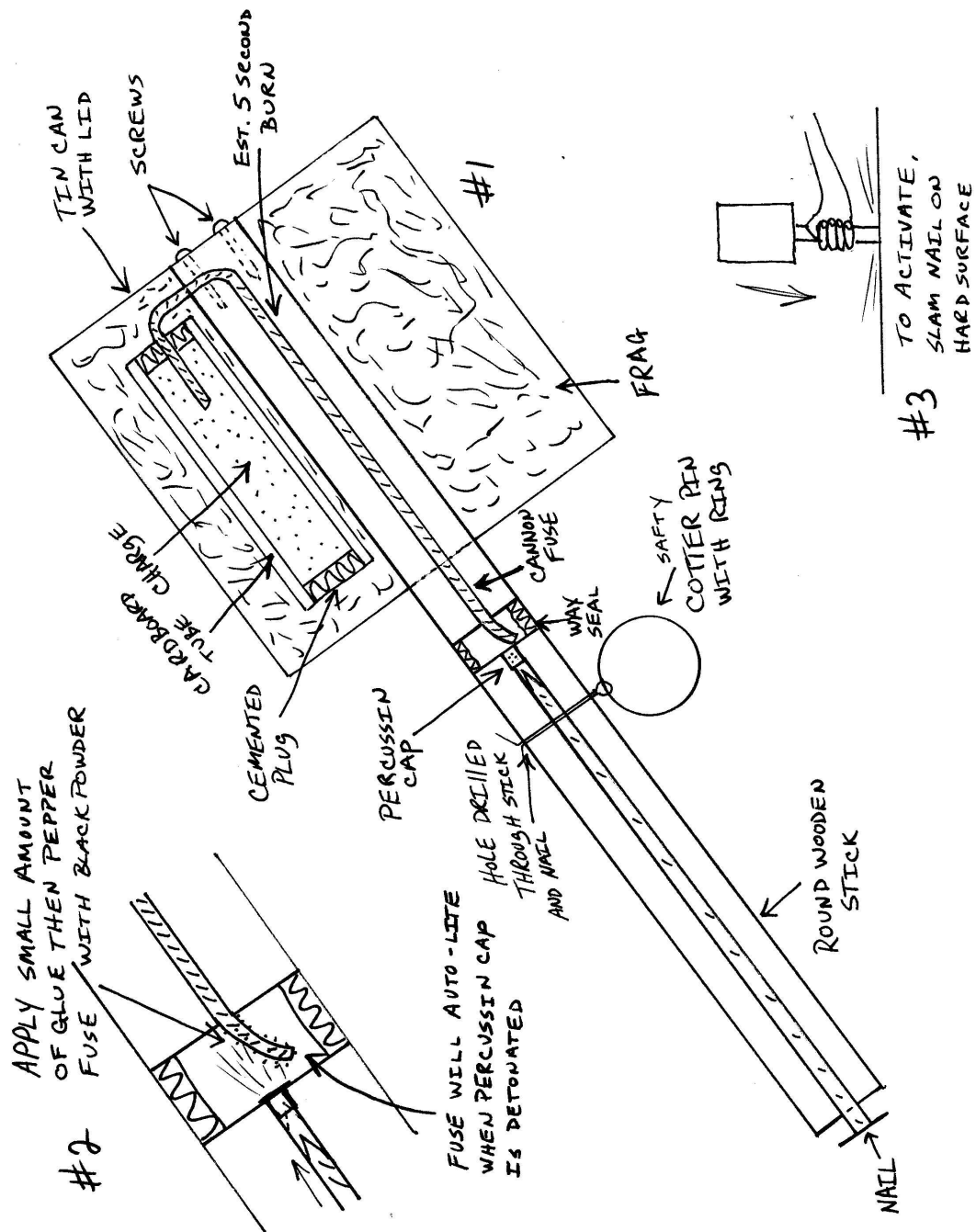

POTATO MASHER GRENADE

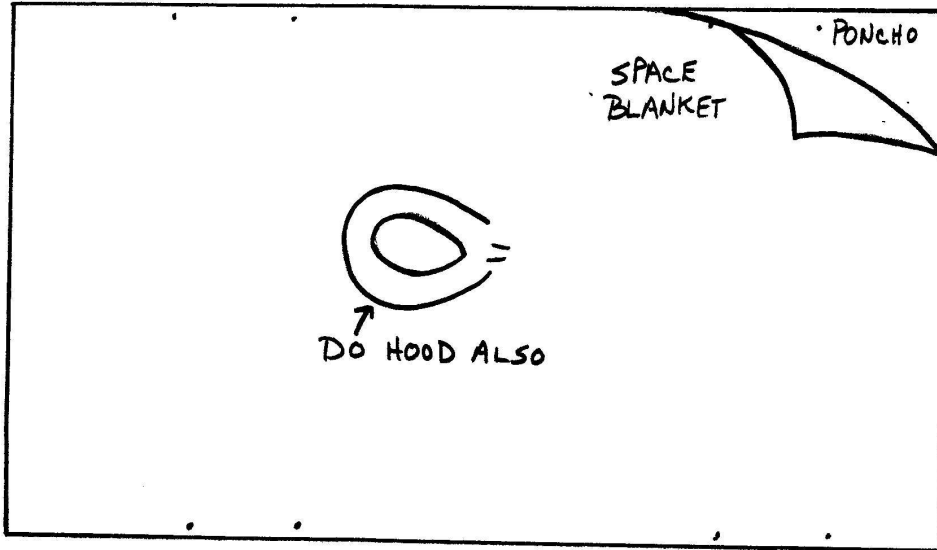

MILITARY-STYLE
RAIN PONCHO WITH
A SPACE BLANKET
(MYLAR) SEWN TO THE
INSIDE.

THE MYLAR REFLEX
98% BODY HEAT BACK
INTO THE BODY.

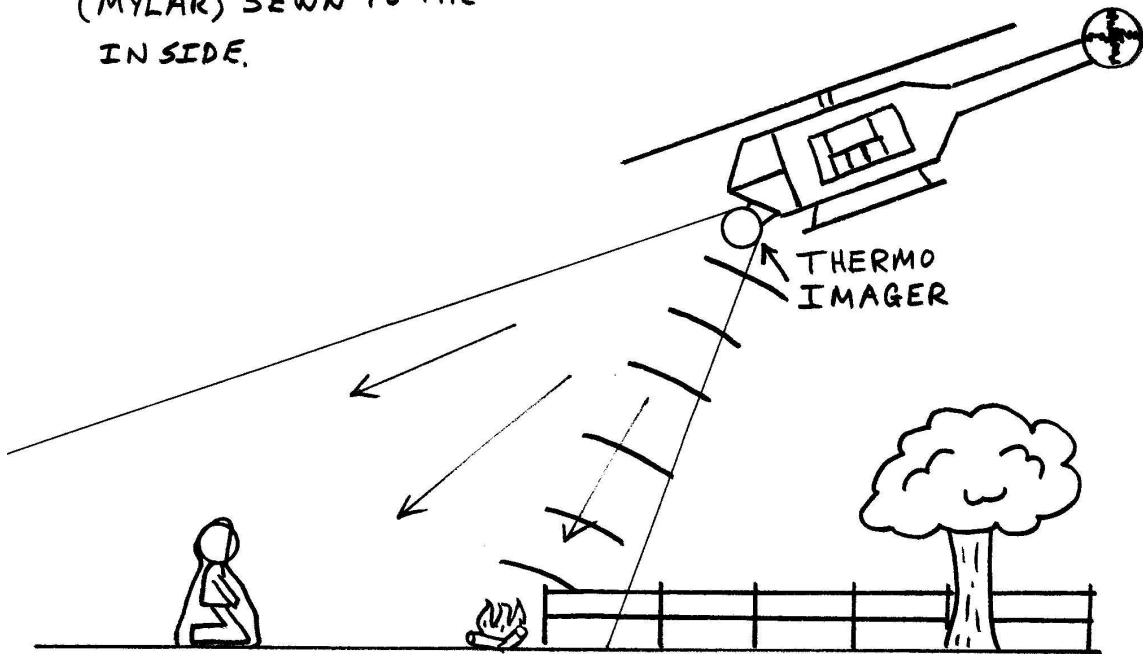

FOOL A THERMO-IMAGER

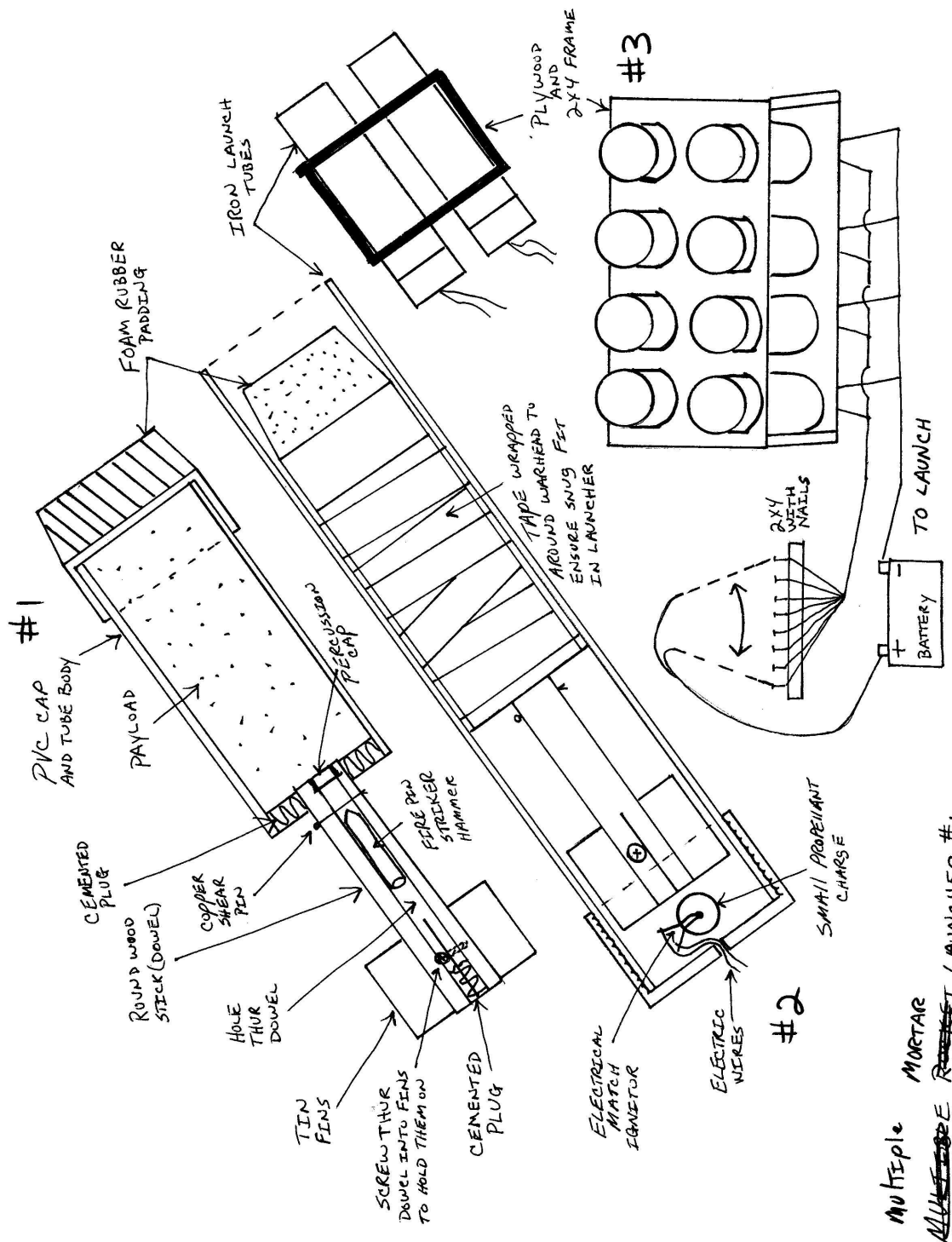

MULTIPLE MORTAR
~~ROCKET~~ LAUNCHER #1

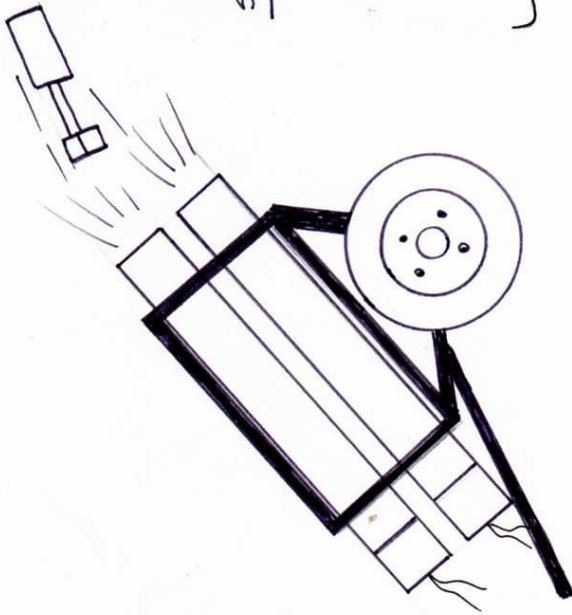
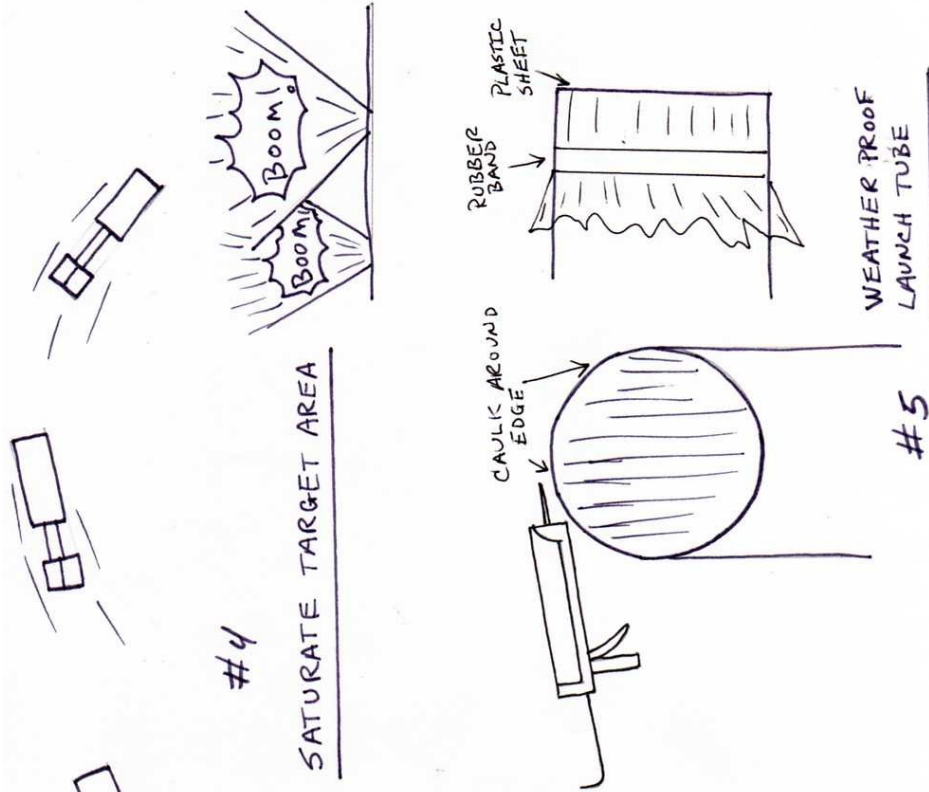

MULTIPLE MORTAR
 MULTIPLE ROCKET LAUNCHER #2

WALL THERMOSTAT

MERCURY SWITCH BULB #1

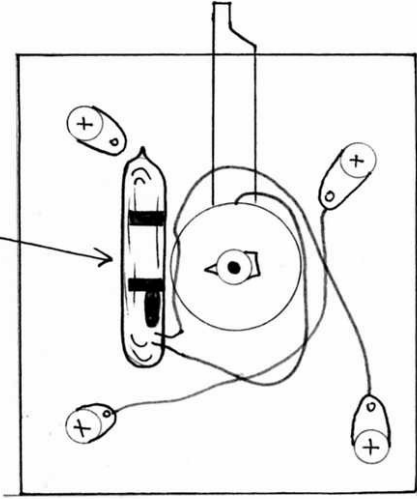

MERCURY #2

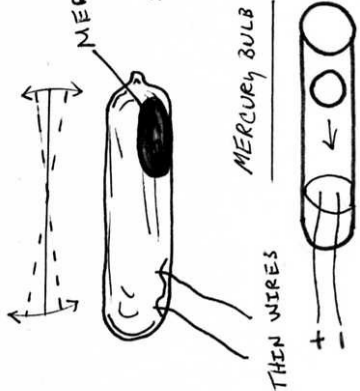

SHAVING CAN BOOBYTRAP

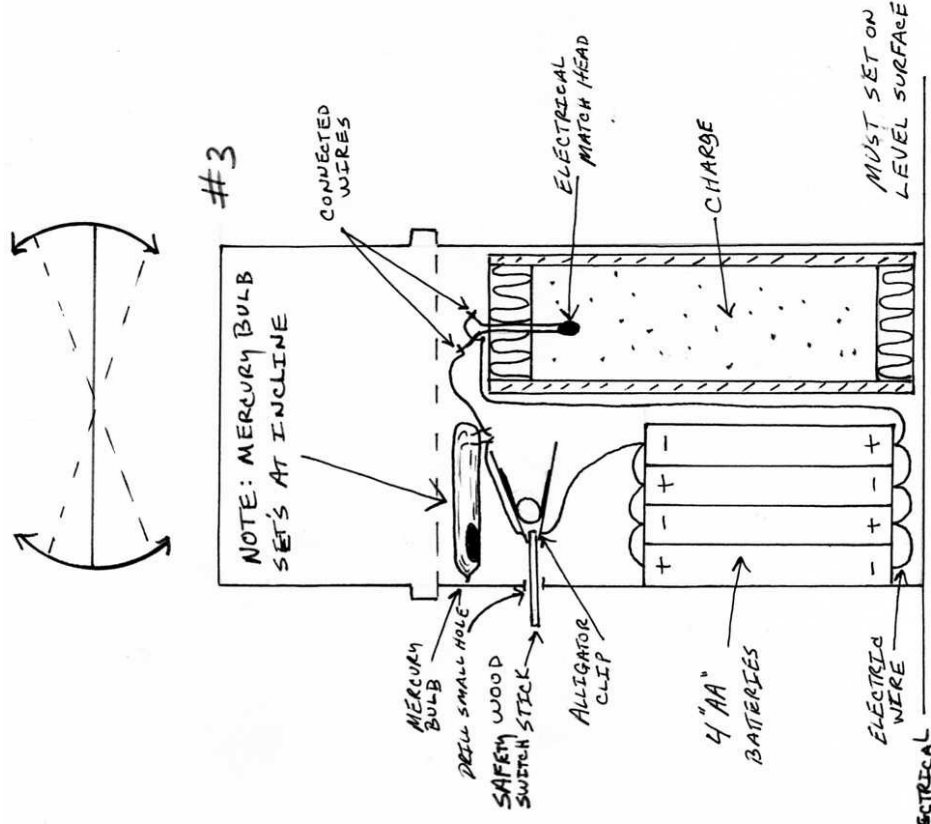

#3

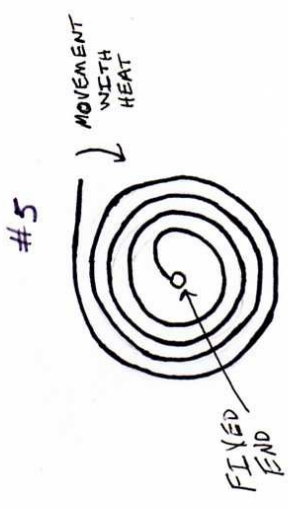
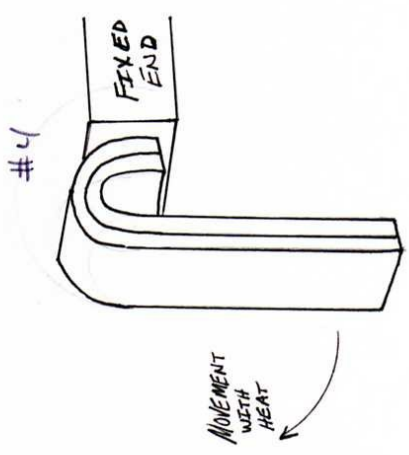
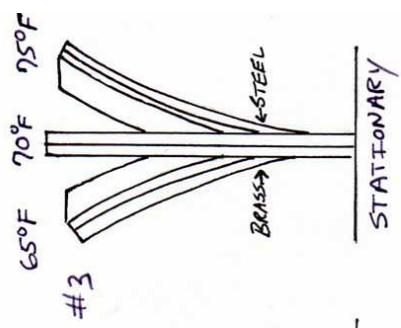
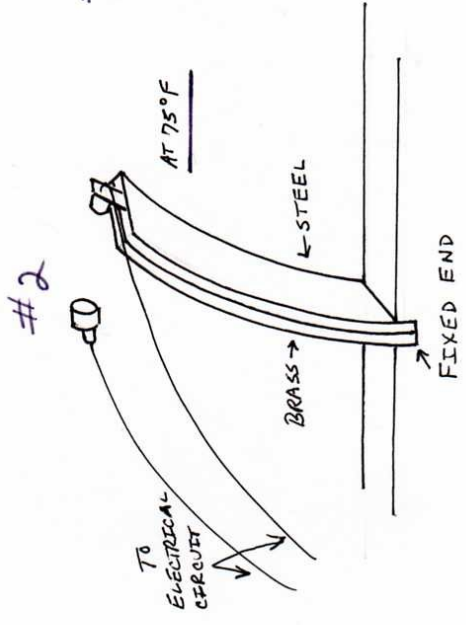
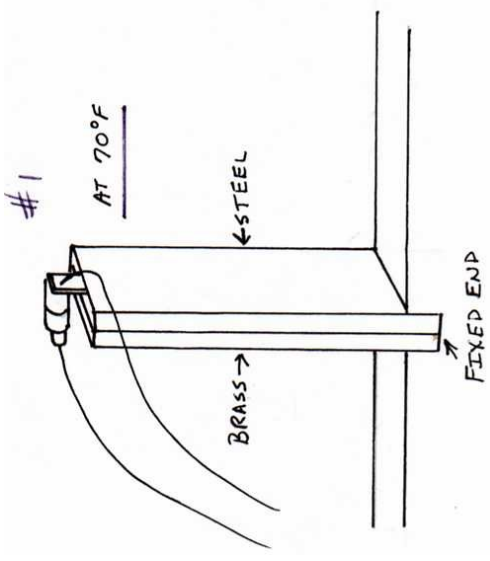

BI-METAL THERMAL DEVICE #1

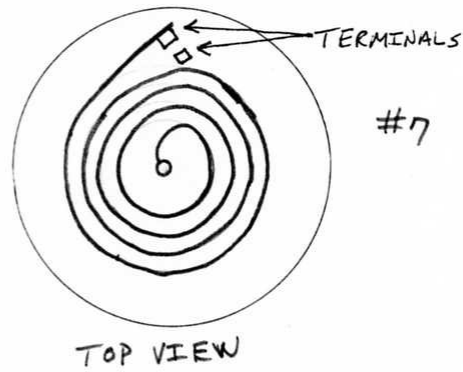
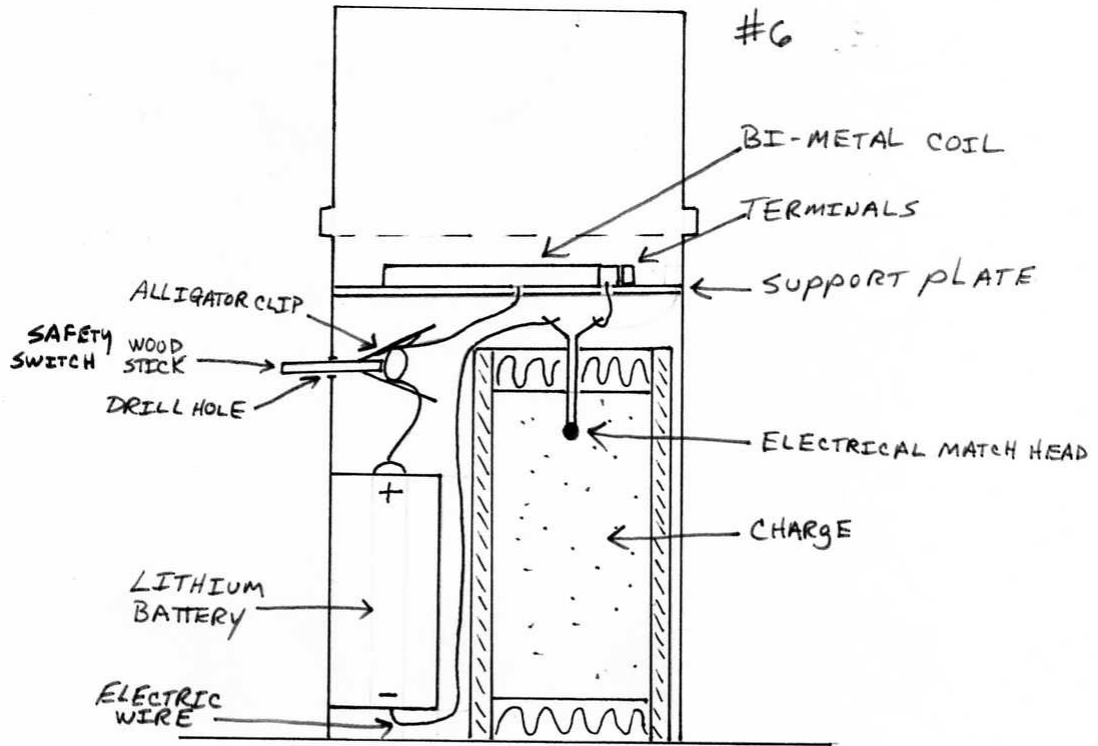

BI-METAL THERMAL DEVICES #2

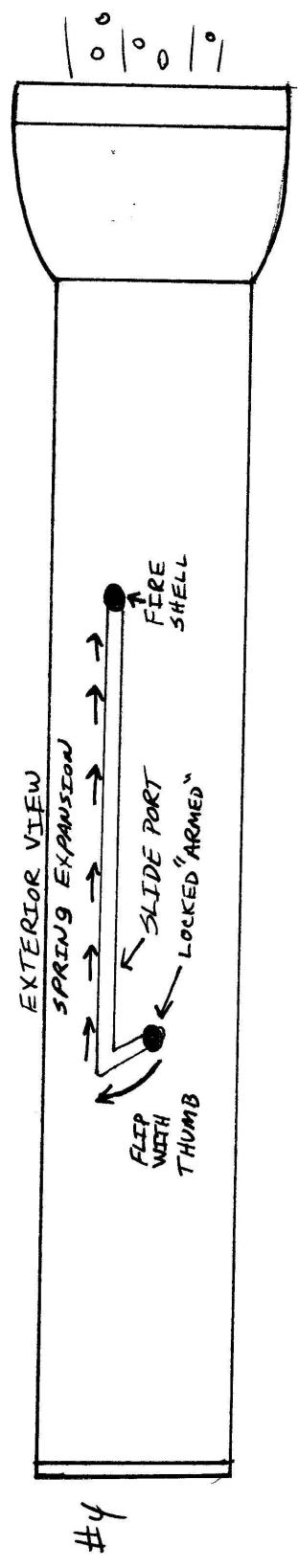
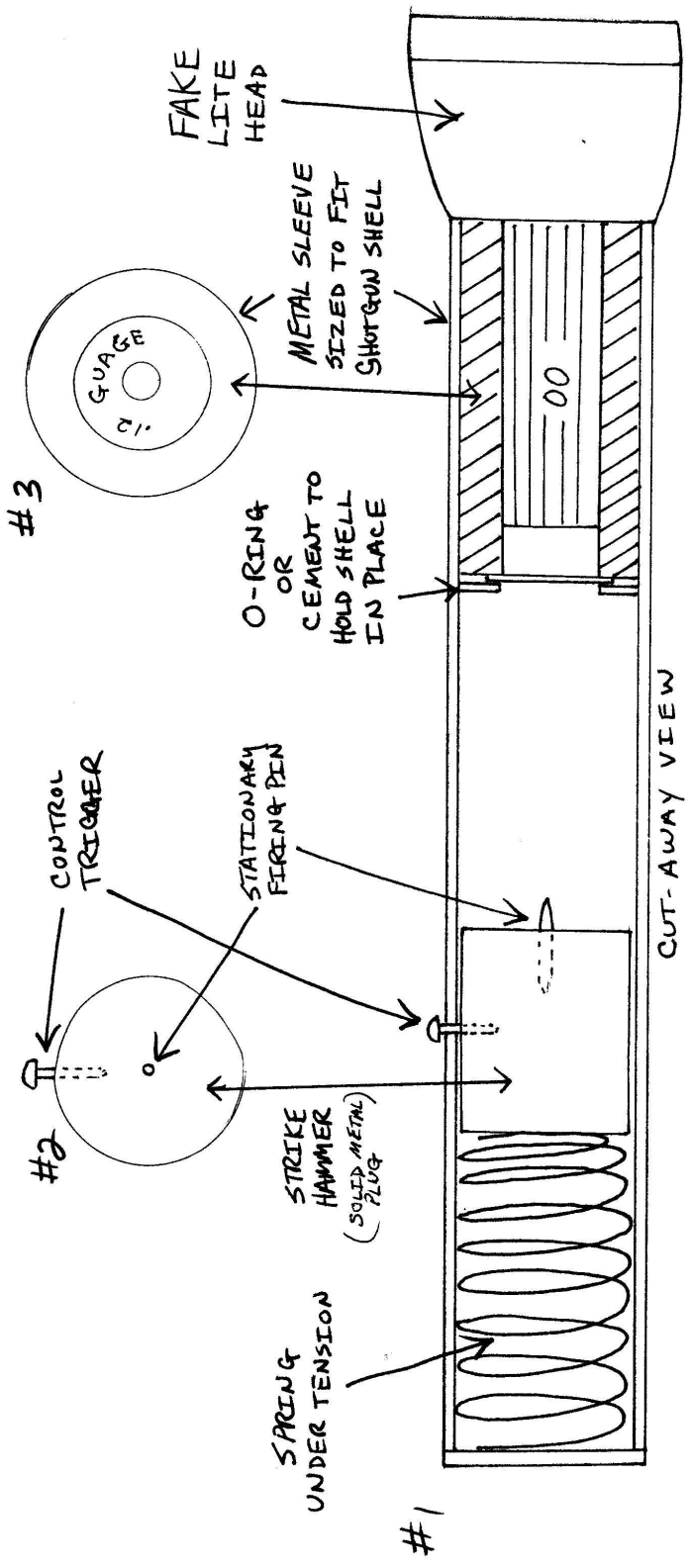

MAG-LITE GUN

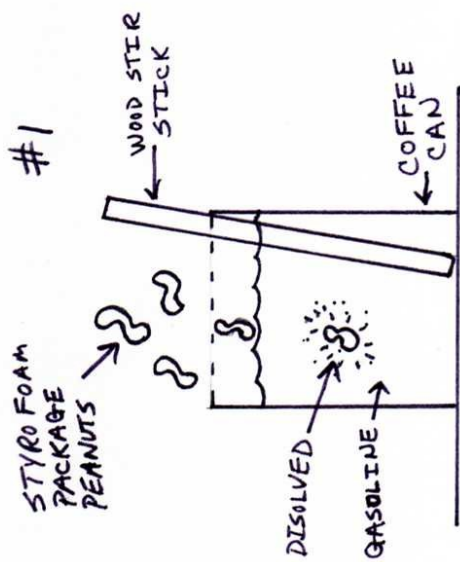
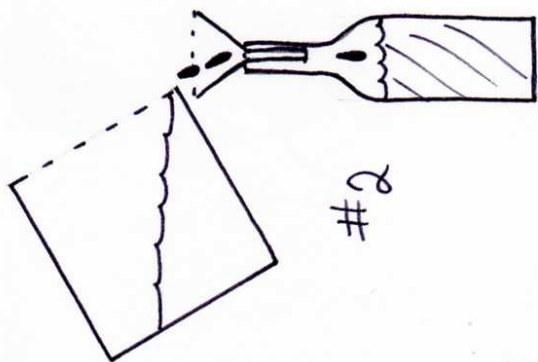
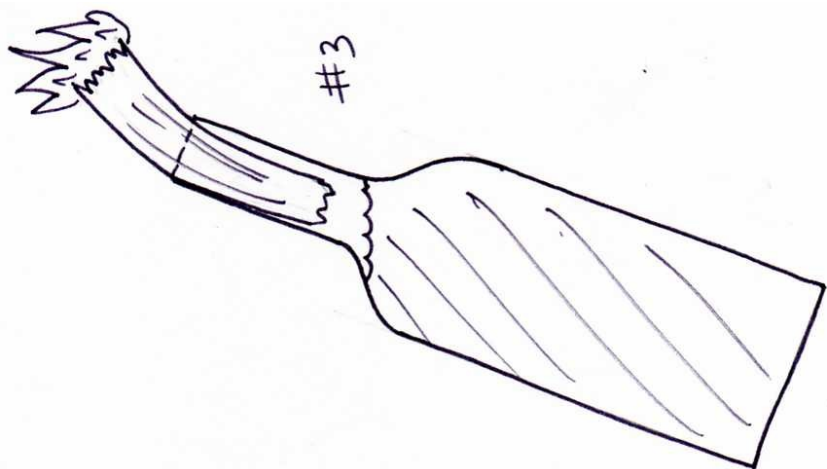

NAPALM

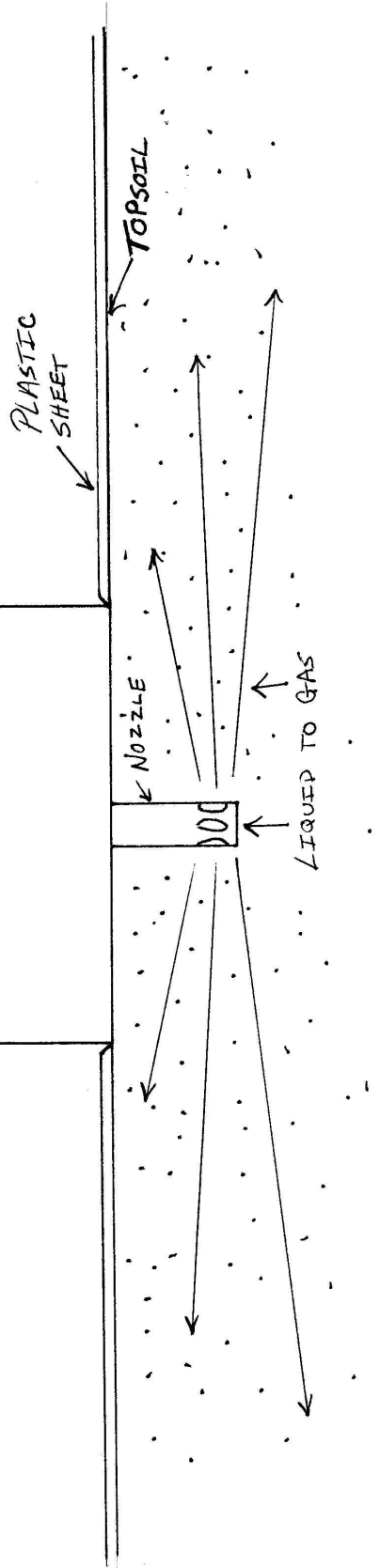
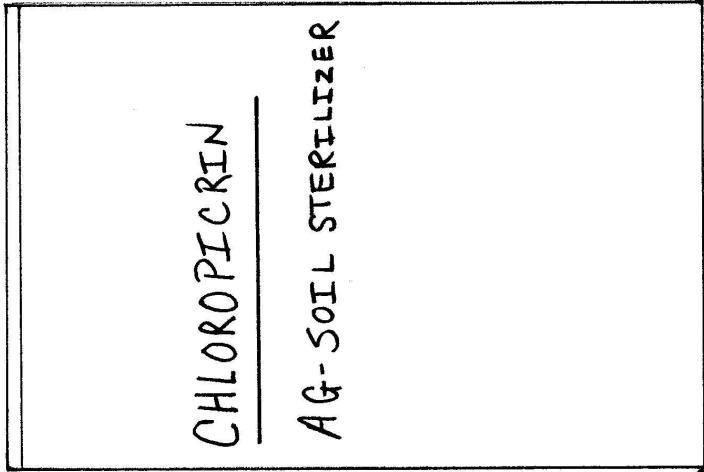
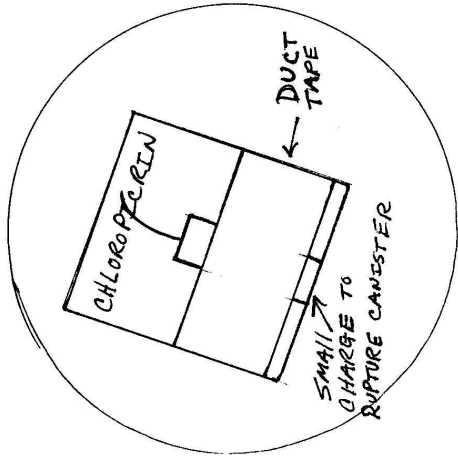

TEAR GAS CANISTER

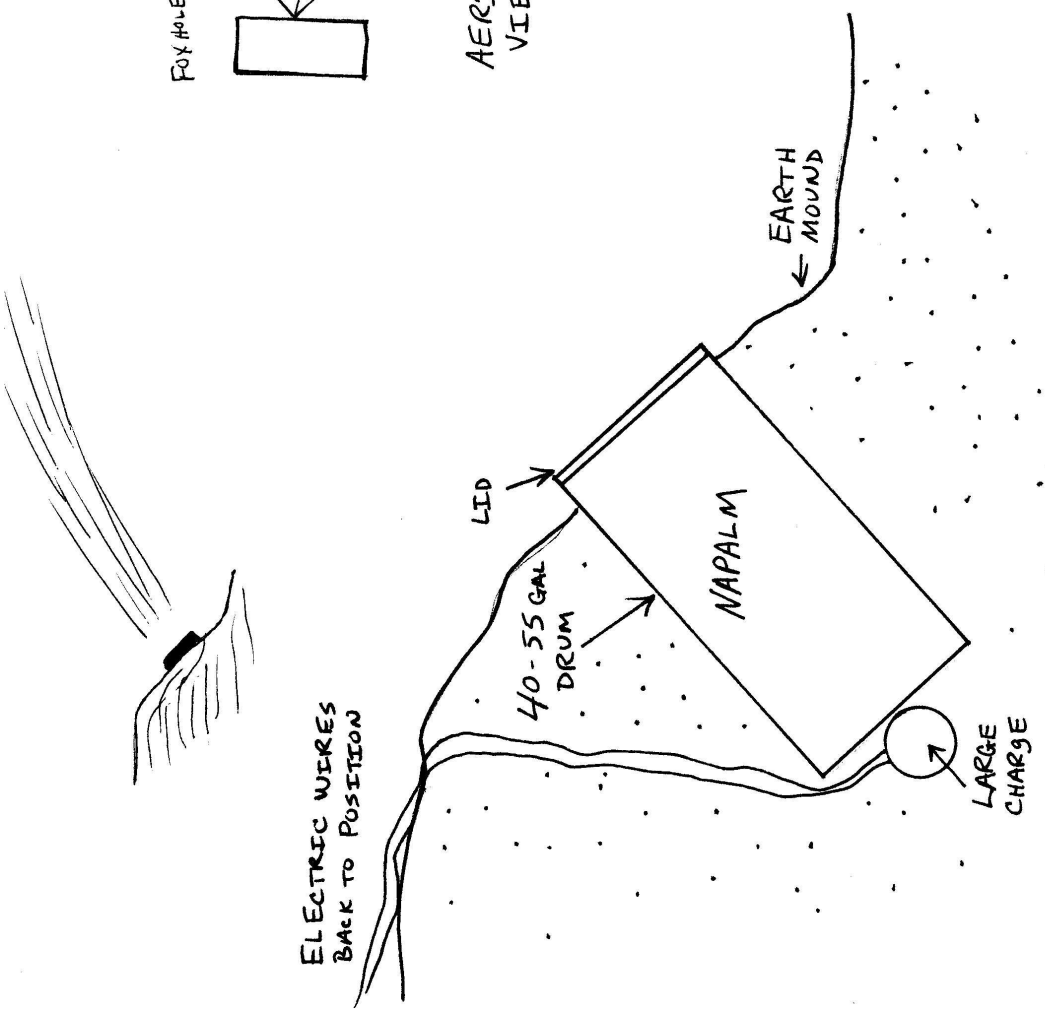
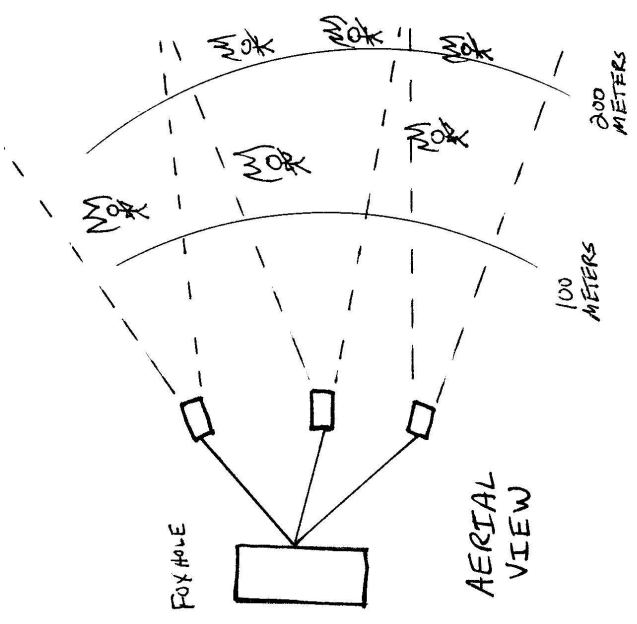

FIRE WALL DEFENSE

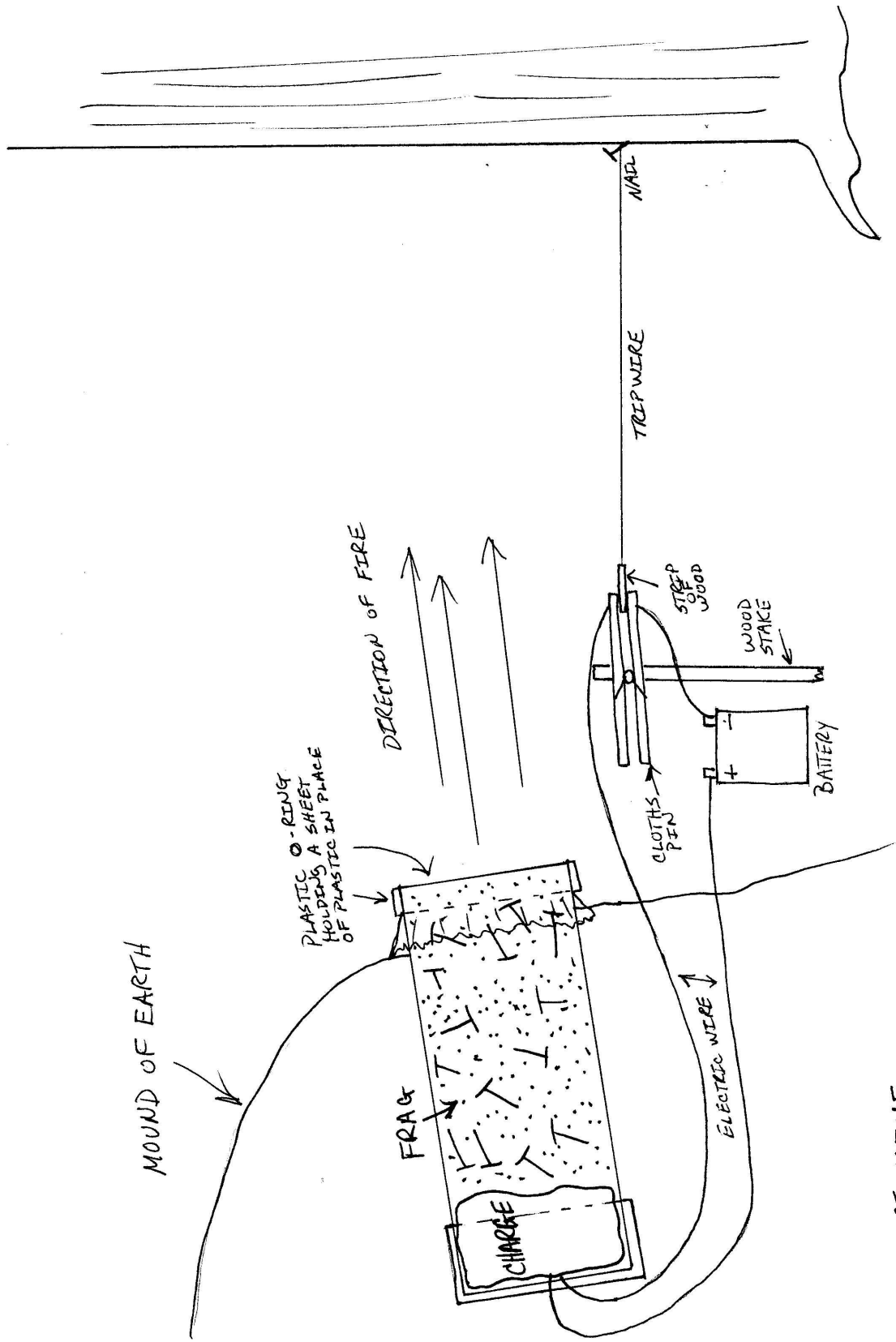

CLAYMORE MINE

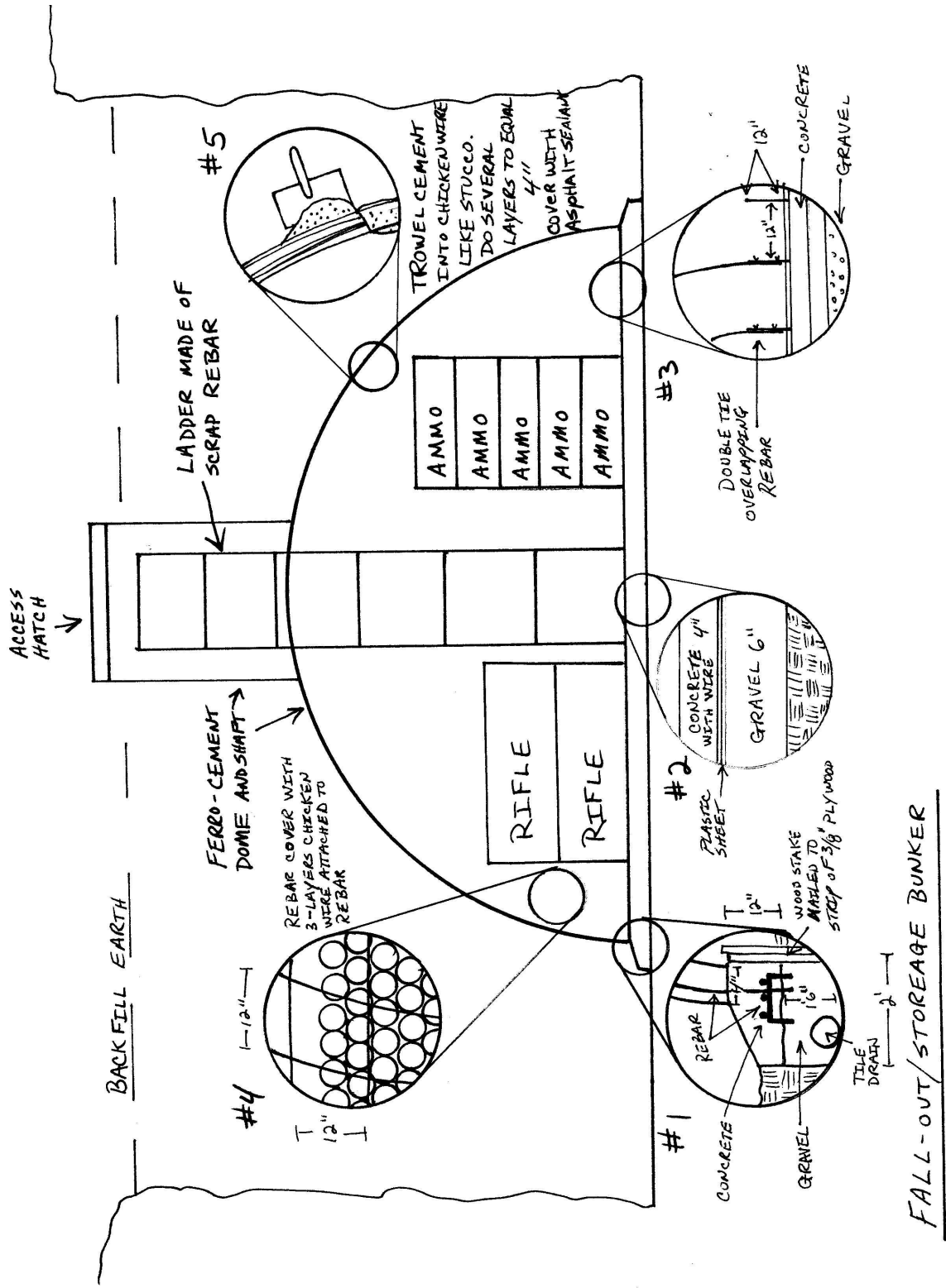

FALL-OUT/STORAGE BUNKER

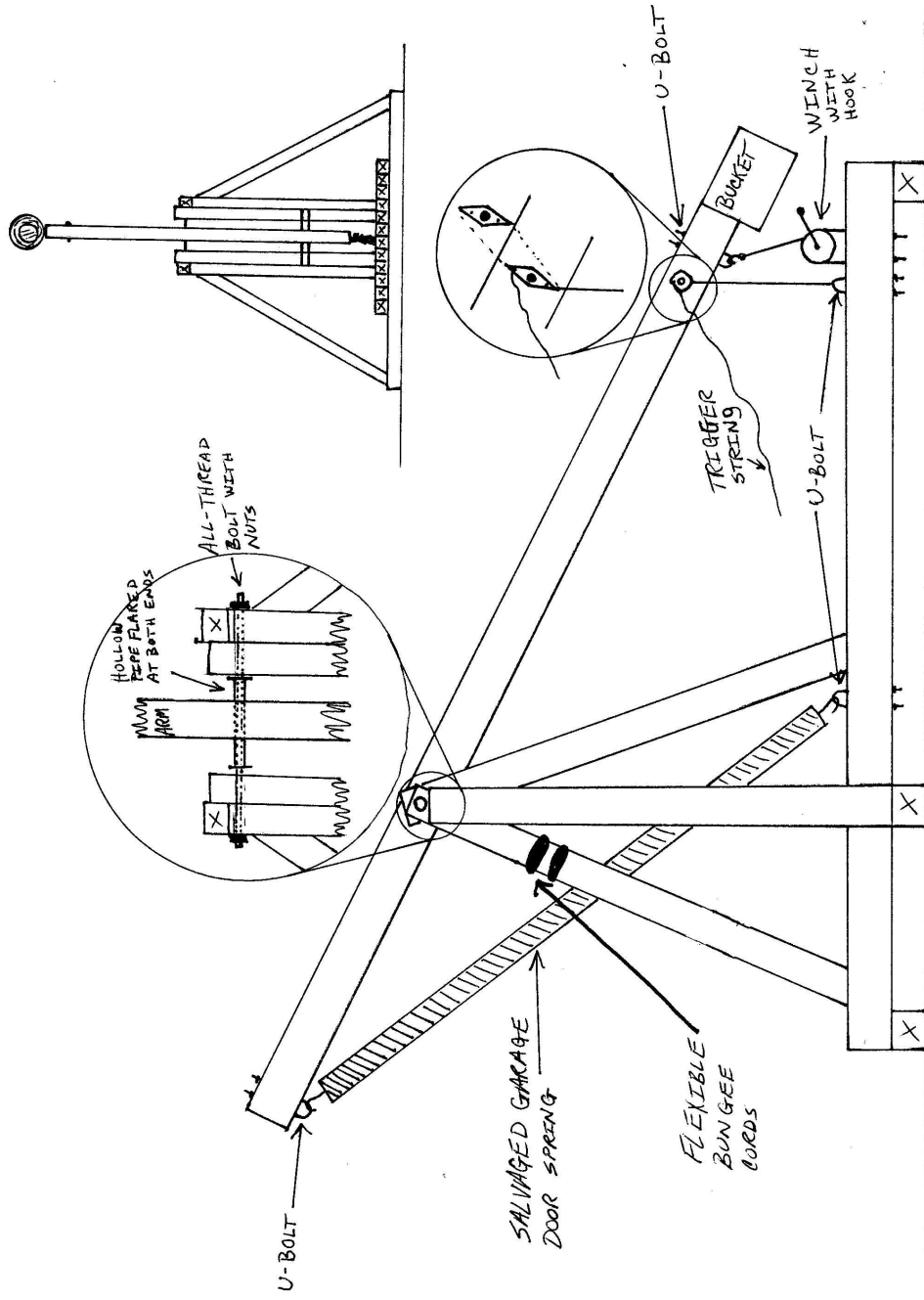

MEDIEVAL CATAPULT ALL 4x4 LUMBER USED

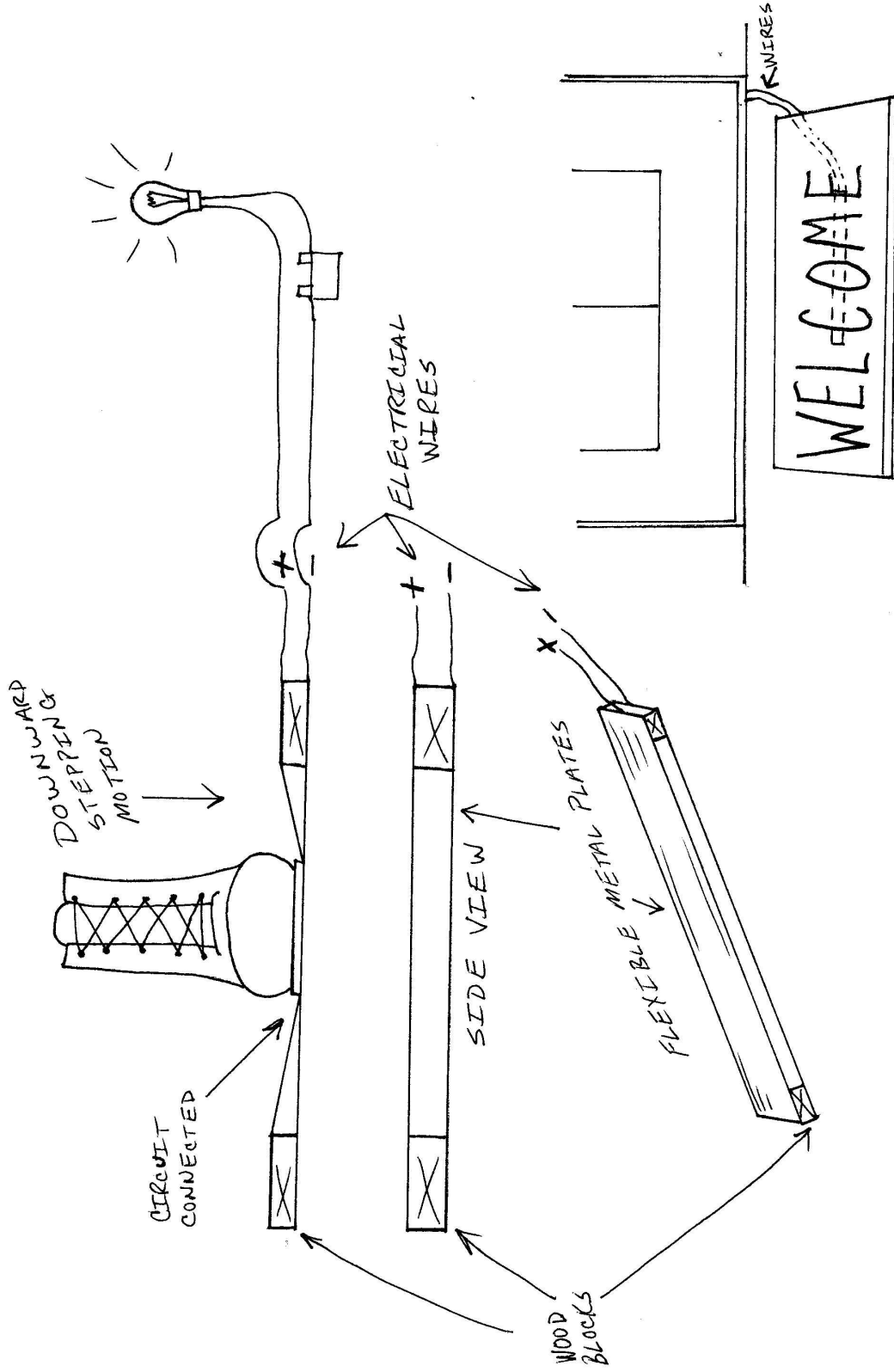

PRESSURE SWITCH

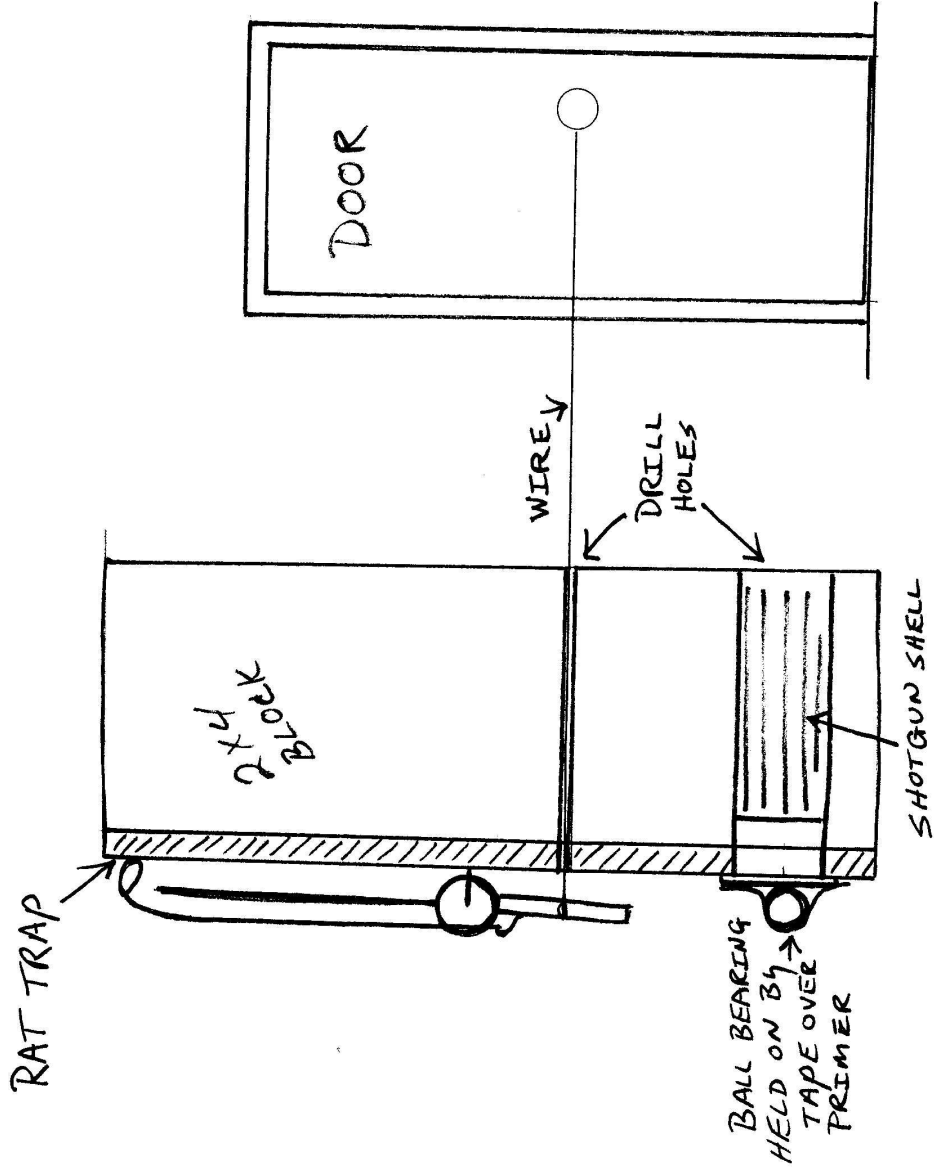

RAT TRAP BOOBYTRAP

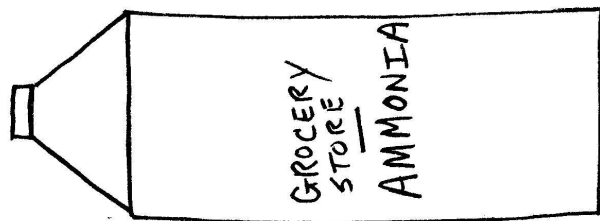
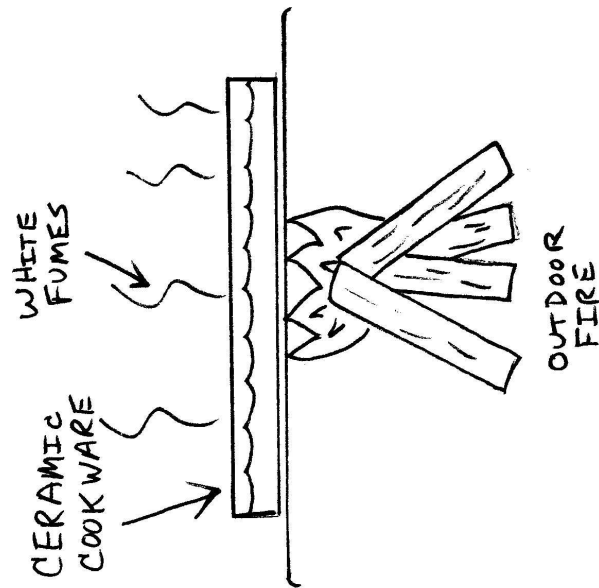
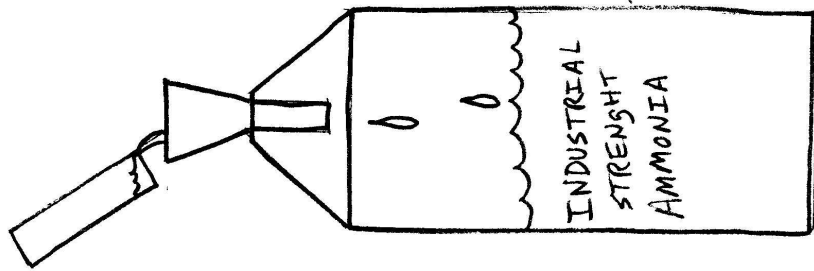

HOW TO MAKE INDUSTRIAL AMMONIA

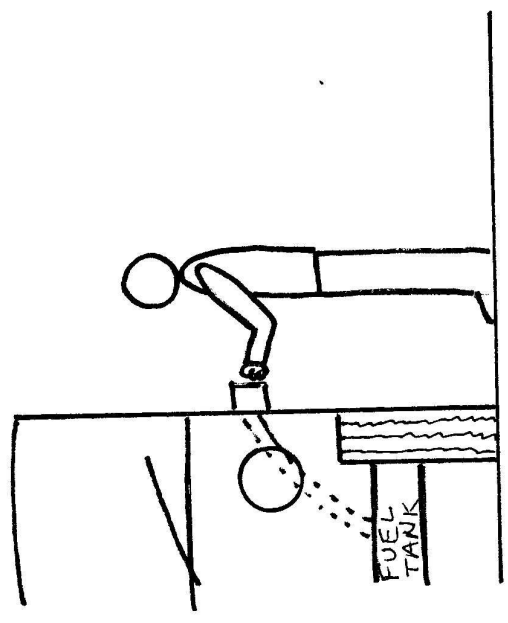
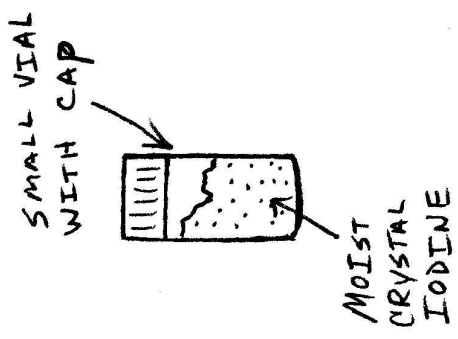
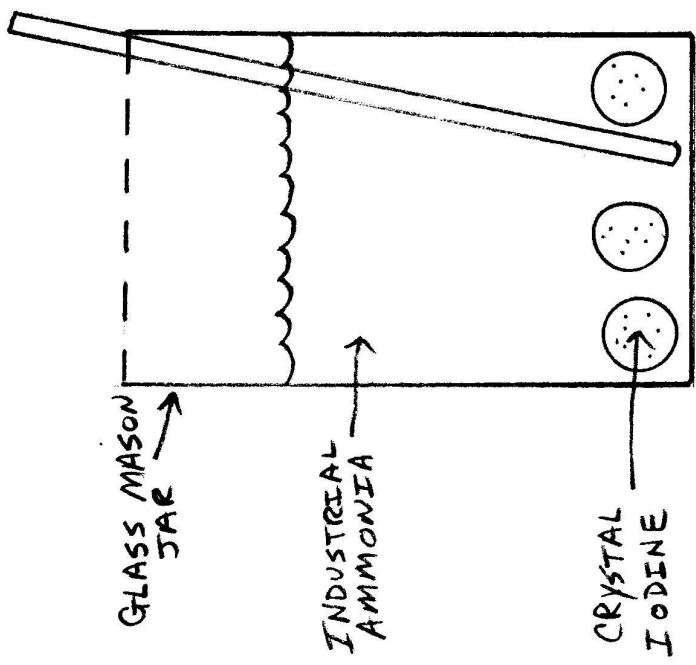

1 GALLON OF GASOLINE
= 75 STICKS OF TNT
WHEN PROPERLY AIRED

VEHICLE WEAPON



AUTOMOBILE LIGHT BULB

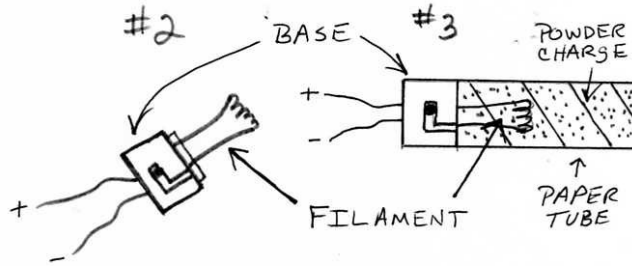

MODEL ROCKET IGNITOR

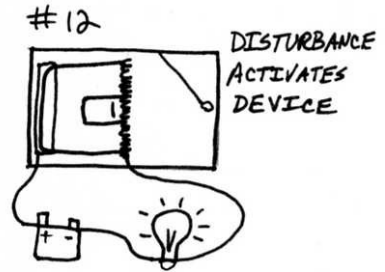
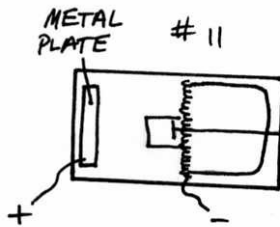
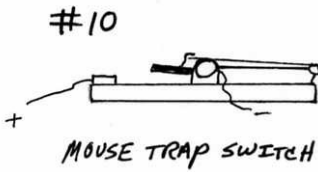
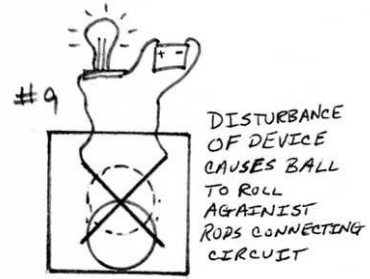
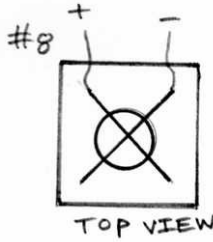
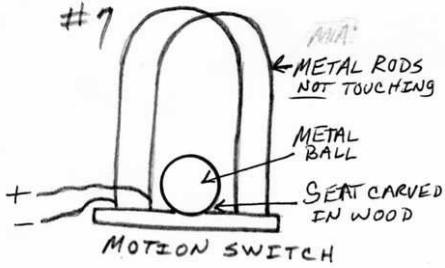
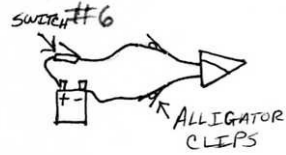
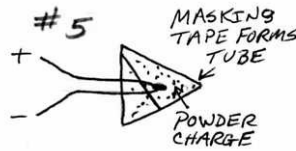

TYPES OF ELECTRICAL IGNITORS

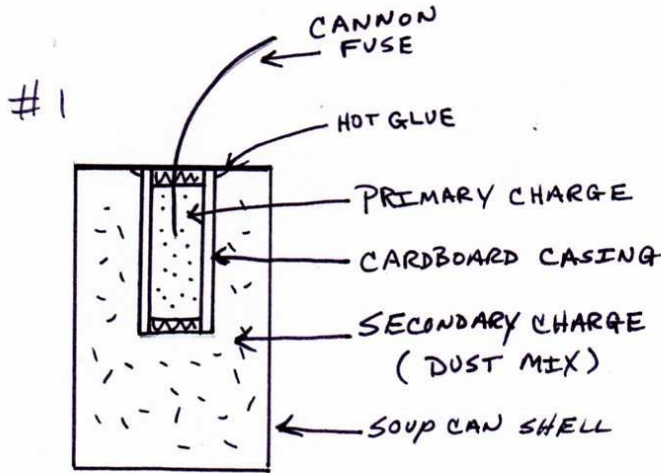

PRIMARY CHARGE

BY VOLUME

80% MAGNESIUM
(350+ MESH)

20% POTASSIUM
CHLORATE

SECONDARY CHARGE

BY VOLUME

1 PART ALUMINUM GRANULAR
(50-100 MESH)

2 PART POTASSIUM CHLORATE

4 PART MAGNESIUM GRANULAR
(50-100 MESH)

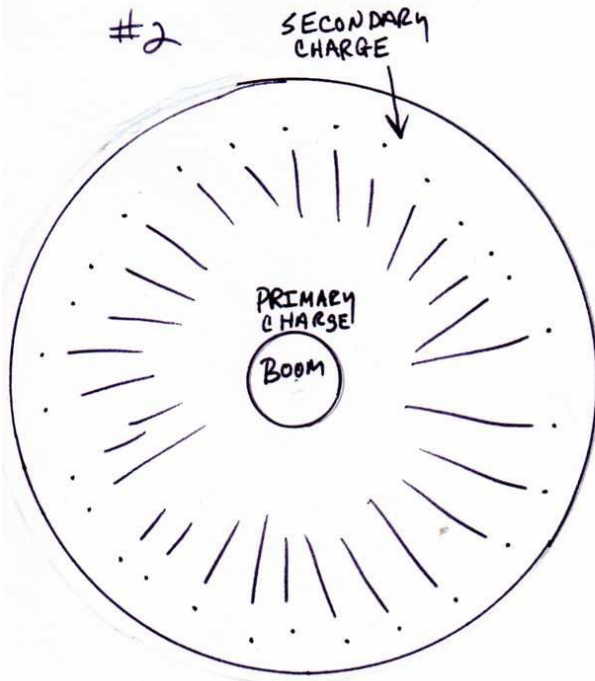

AKA. TINY NUKE
DUST EXPLOSIVE

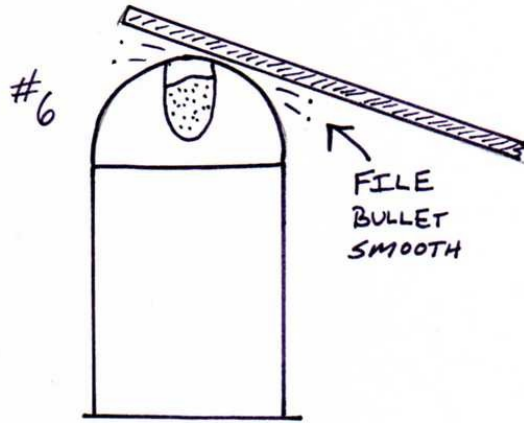
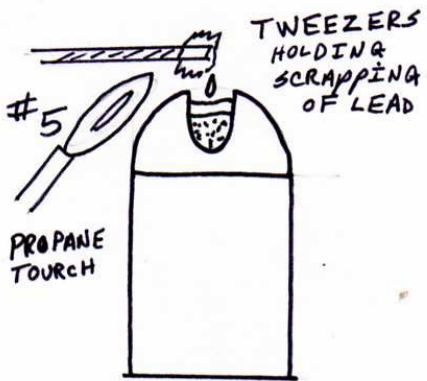
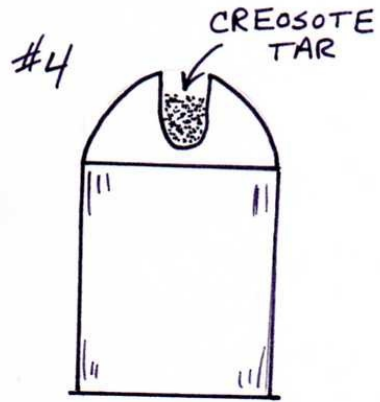
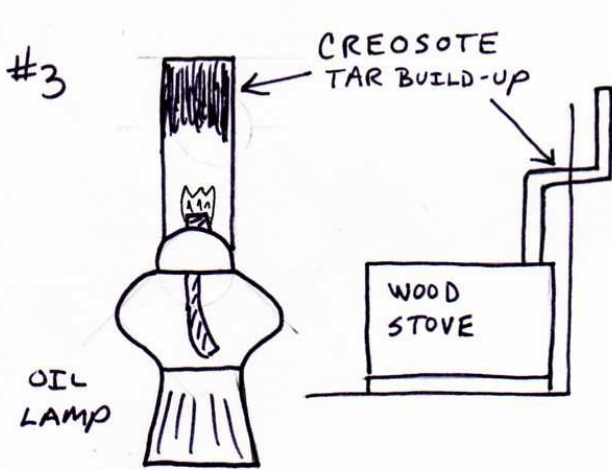
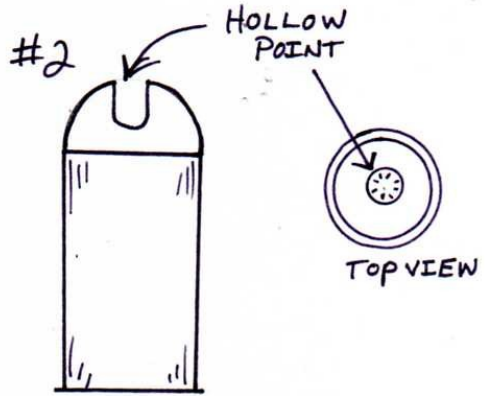
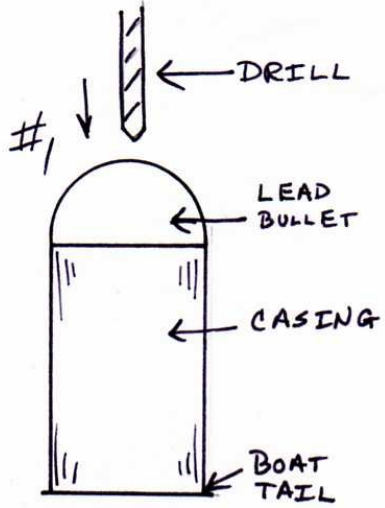

POISON TIP BULLETS

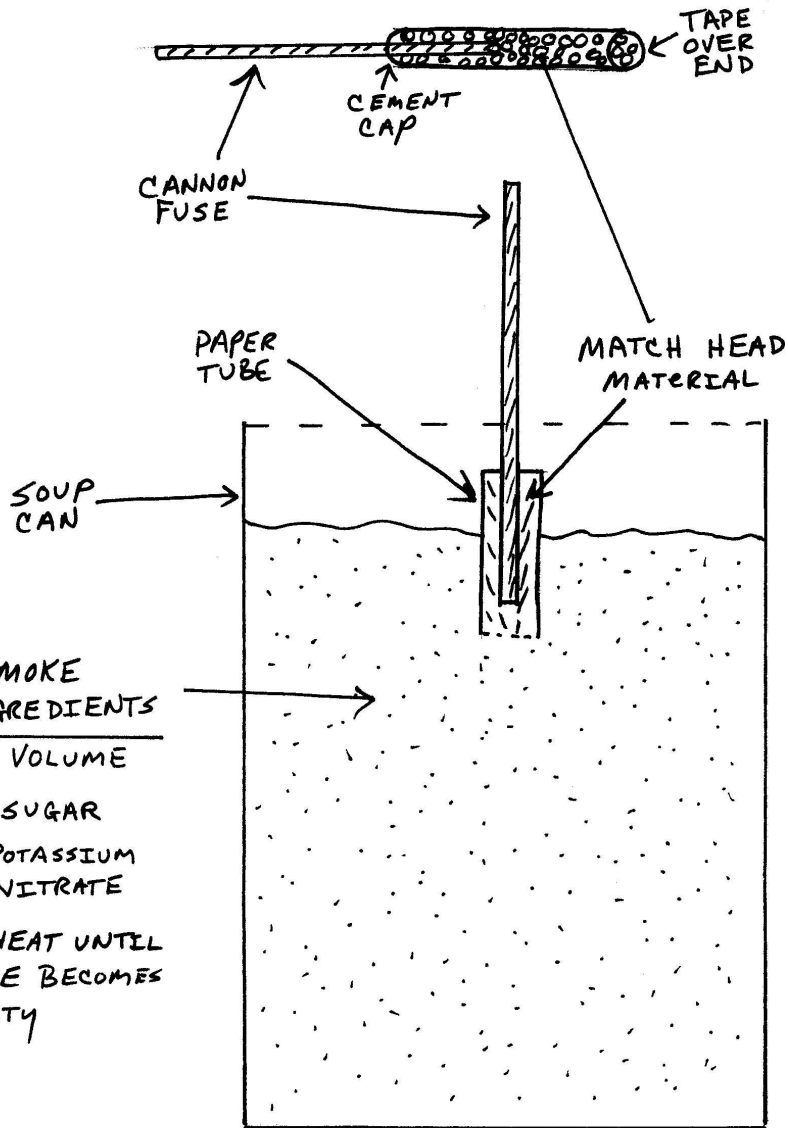

DO NOT ALLOW
MIX TO DRY
CAKE TO SIDE
OF CAN WHEN
COOKING. IT
MAY IGNITE!

SMOKE
INGREDIENTS
BY VOLUME

6 PART SUGAR
4 PART POTASSIUM
NITRATE

SLOW HEAT UNTIL
MIXTURE BECOMES
SOLIDITY

SMOKE GRENADE

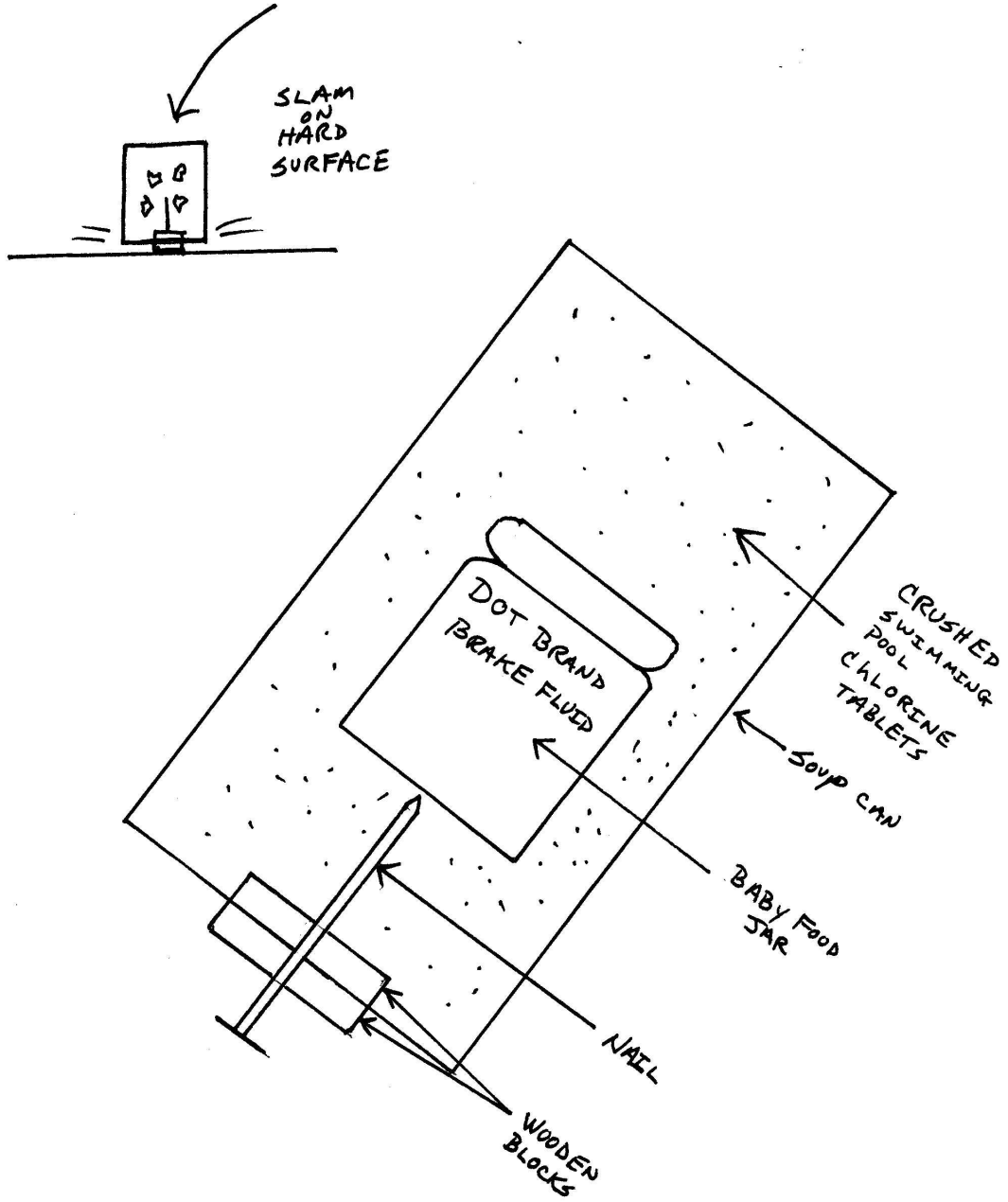

FLARE GRENADE

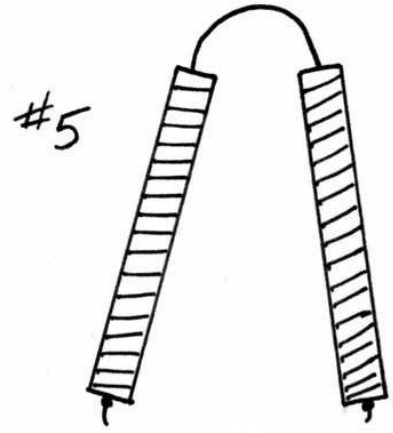
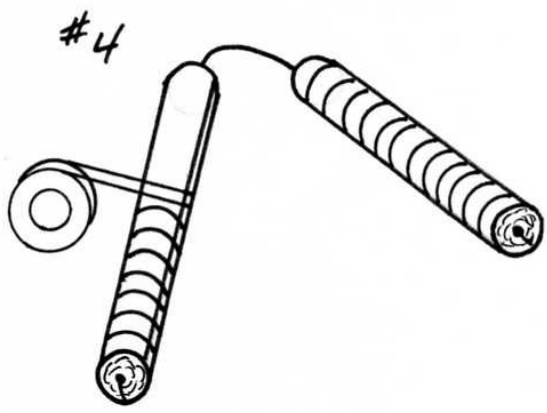
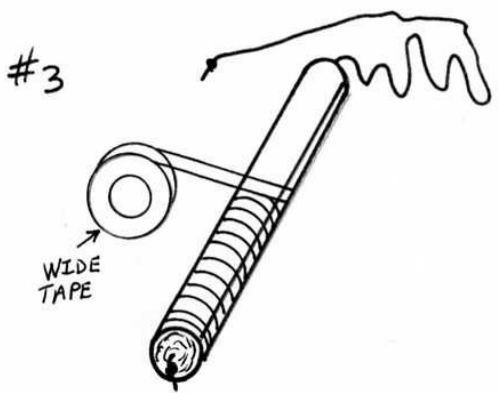
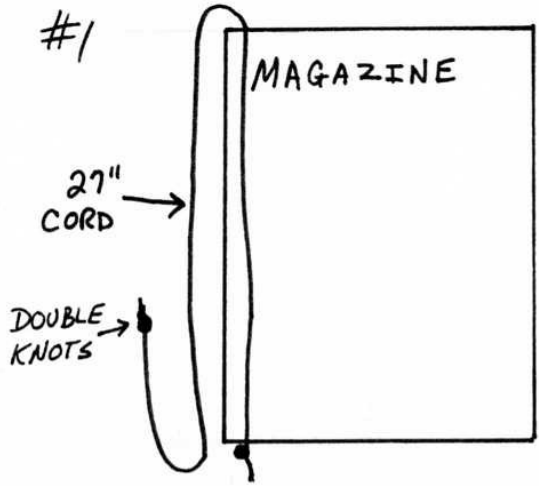

HOMEMADE NUN-CHUCKS

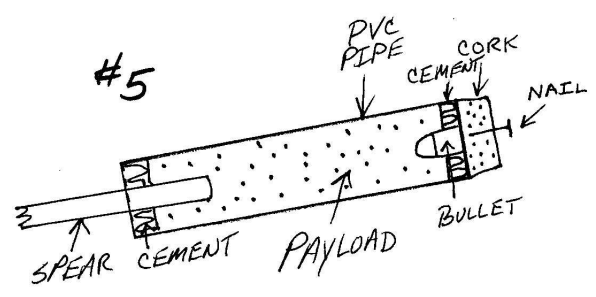
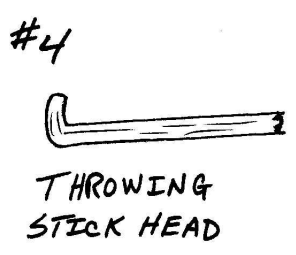
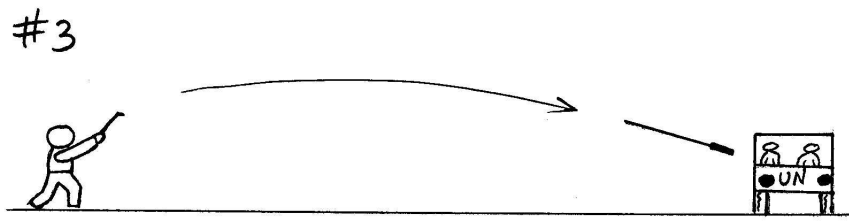
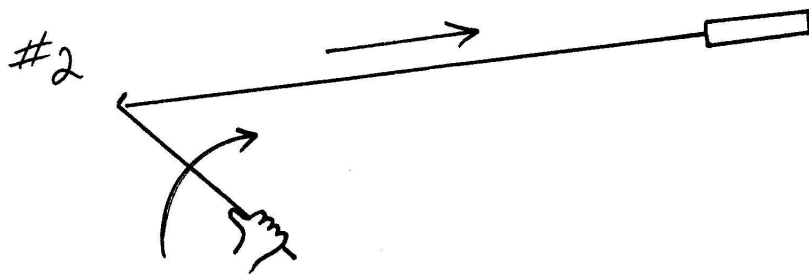
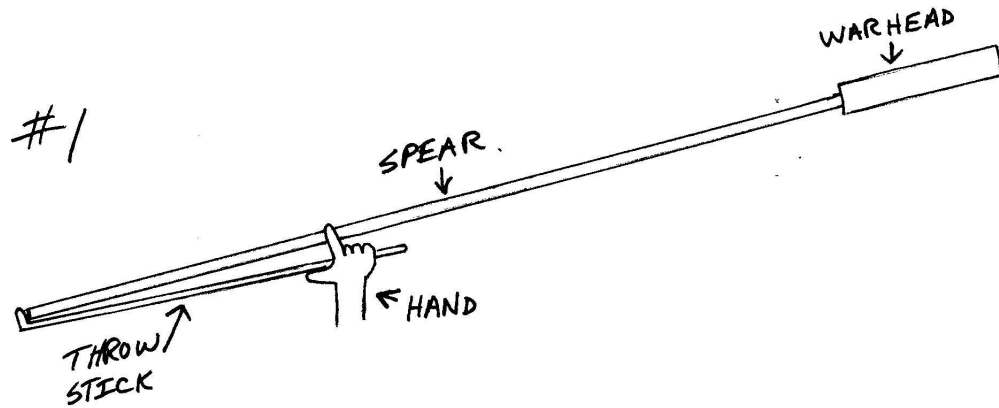

THROWING SPEAR

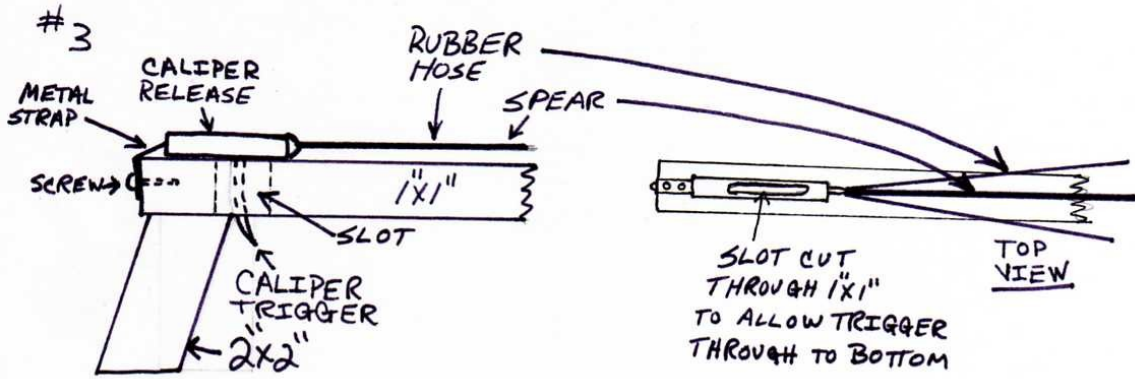
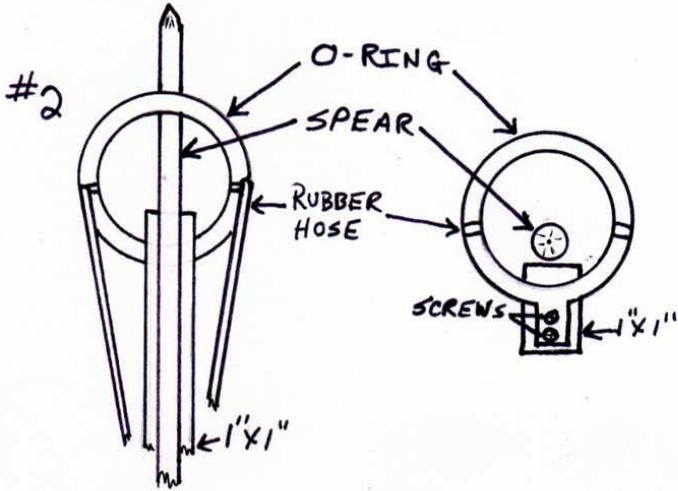
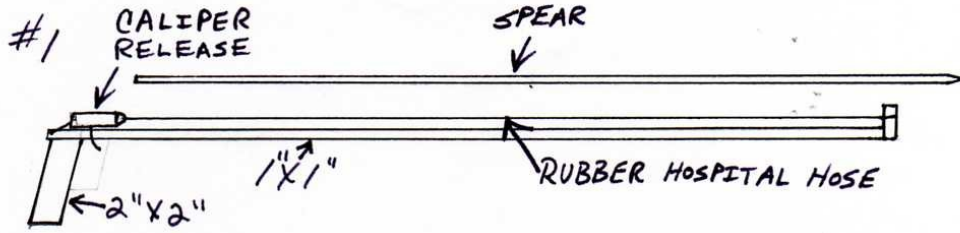

SPEAR GUN #1

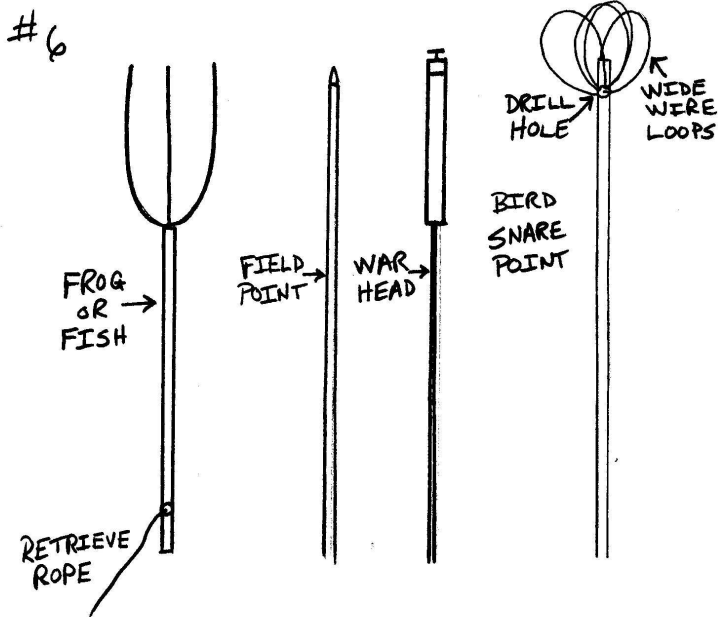
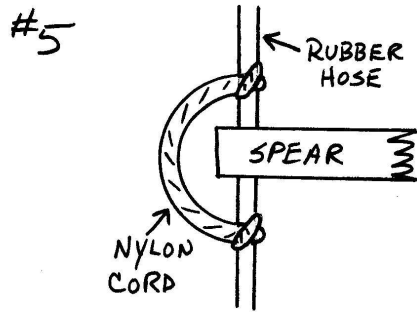
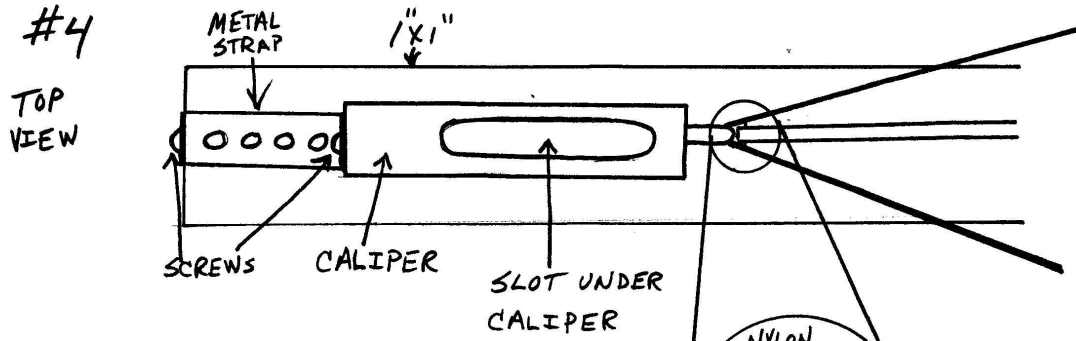

SPEAR GUN #2

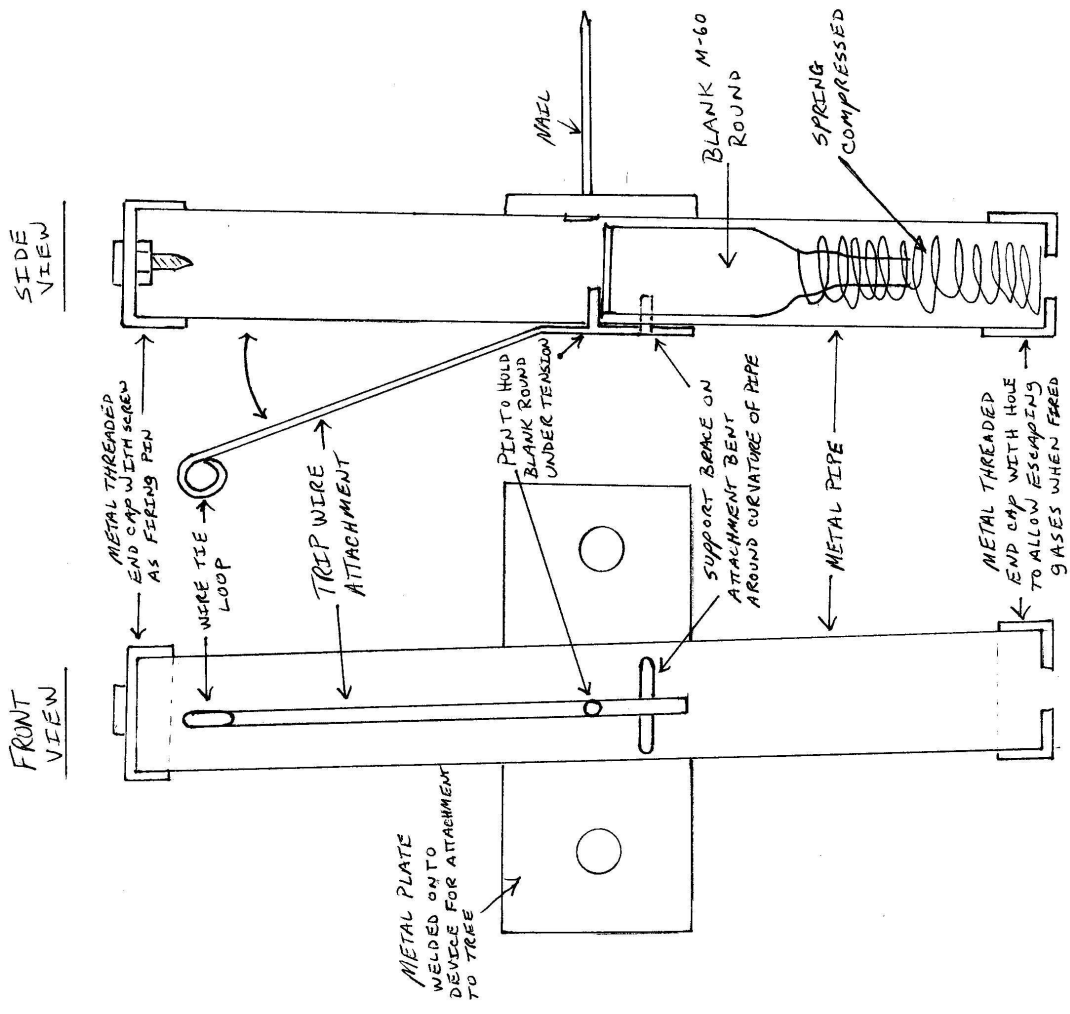
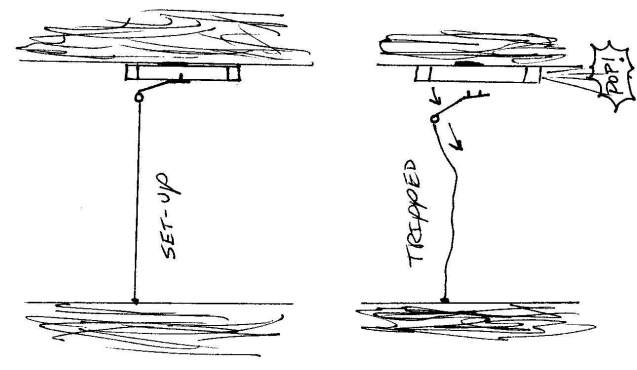

TRIP-WIRE ALERT DEVICE

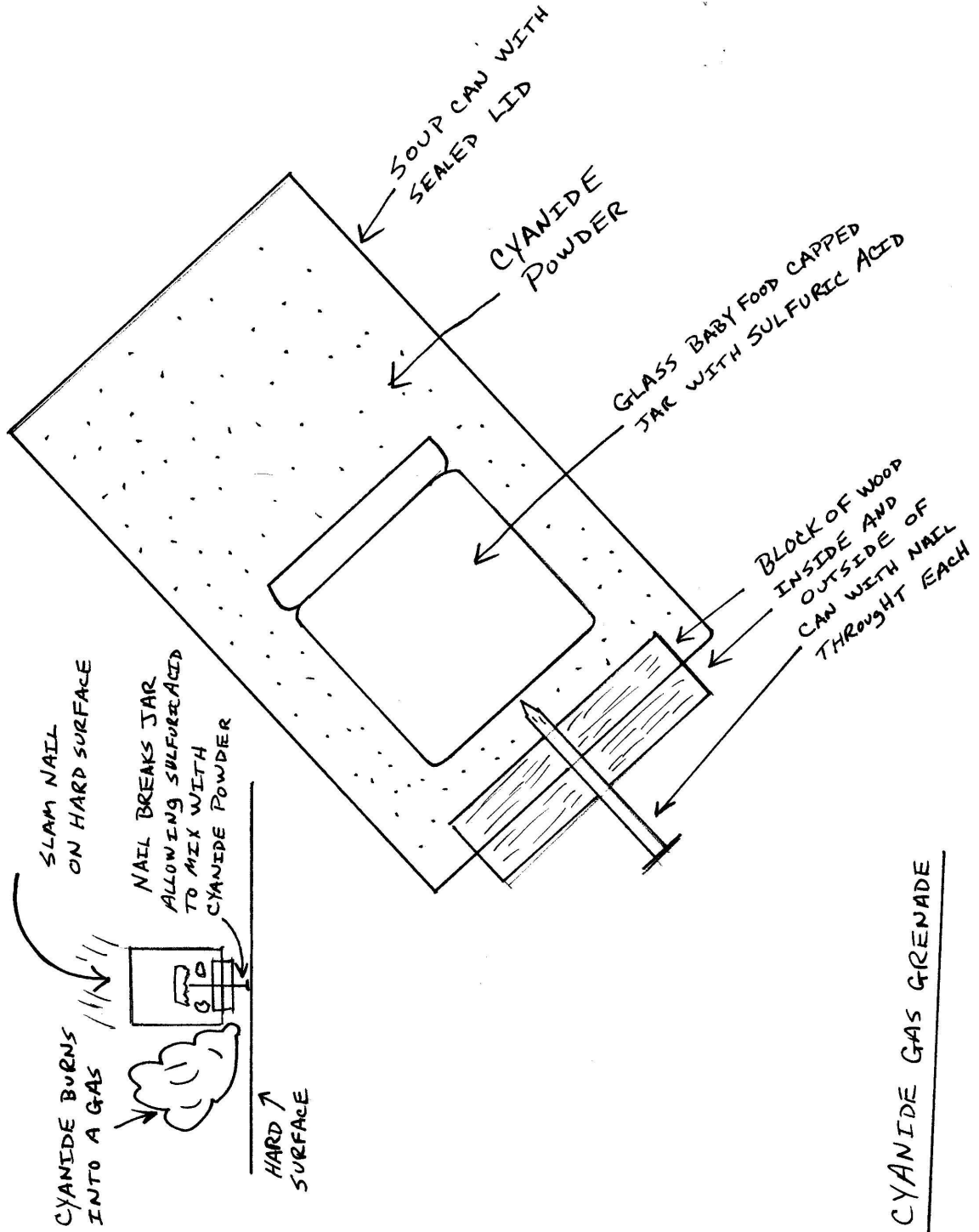

CYANIDE GAS GRENADE

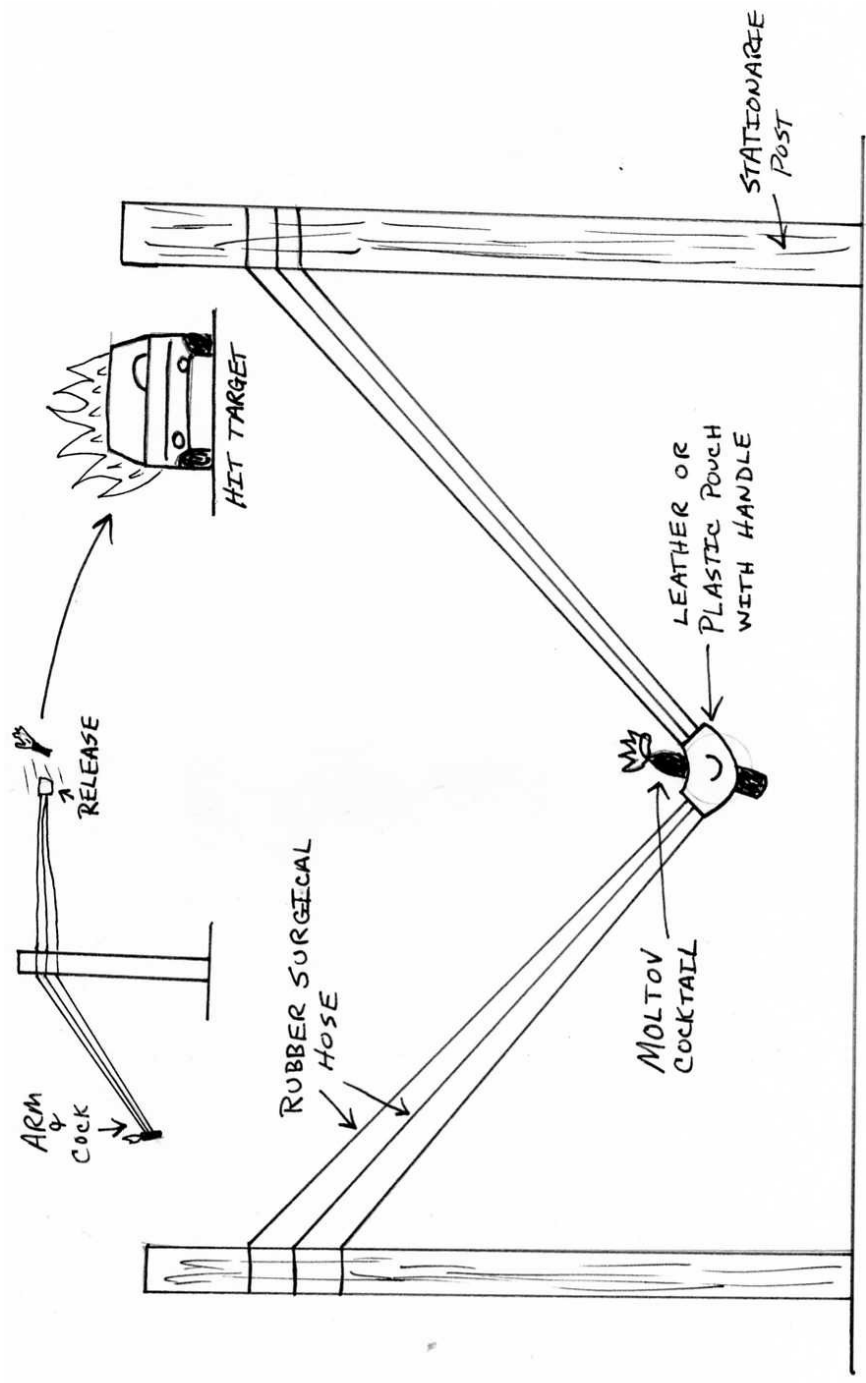

GIANT SLING SHOT

#3

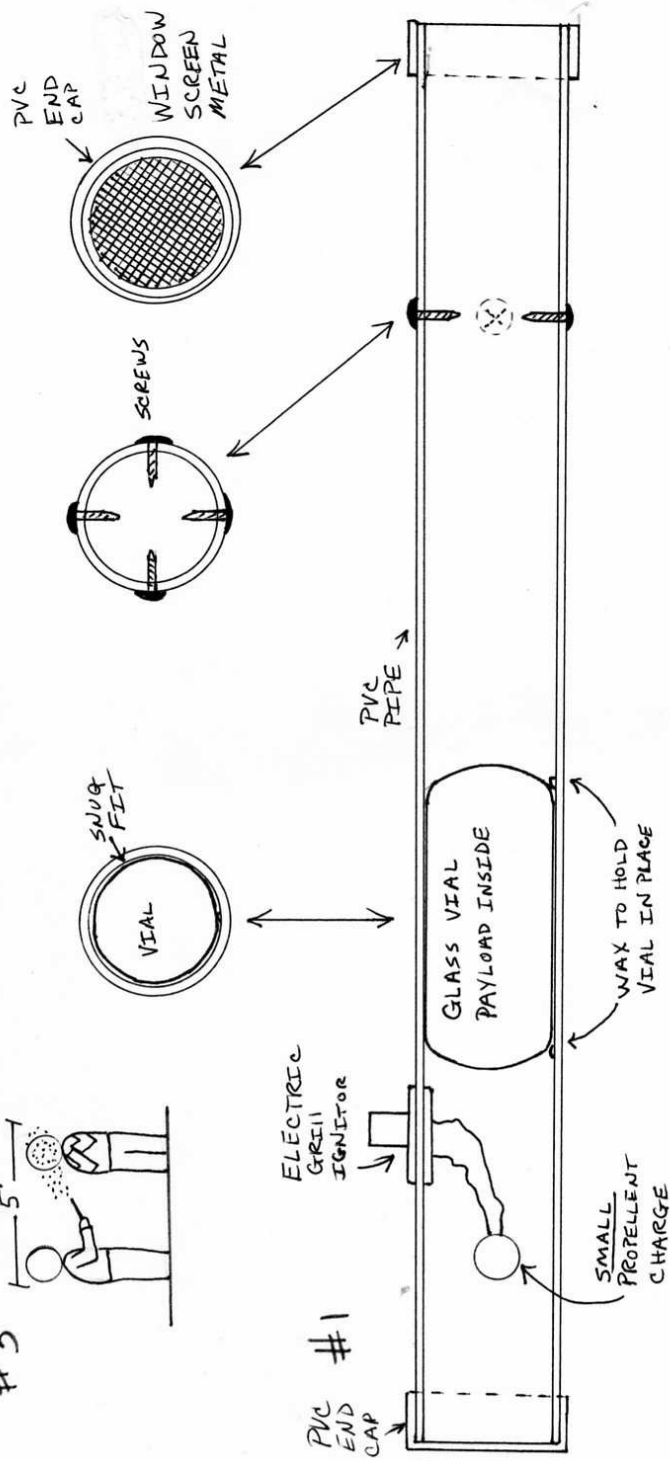

#2

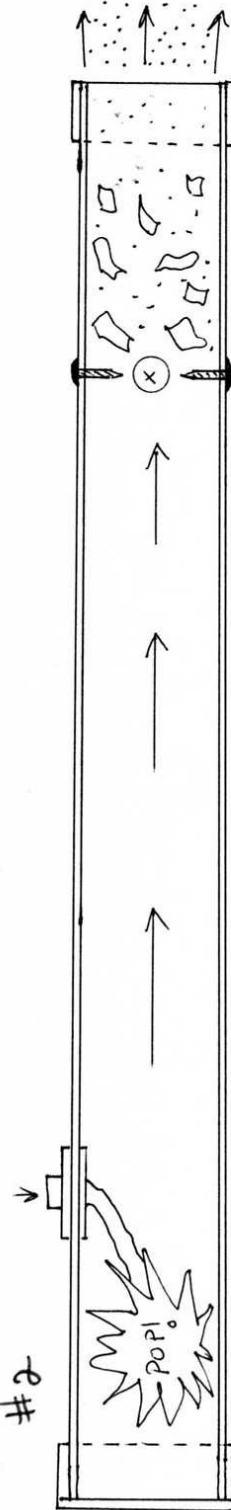

CHEMICAL PISTON STACK

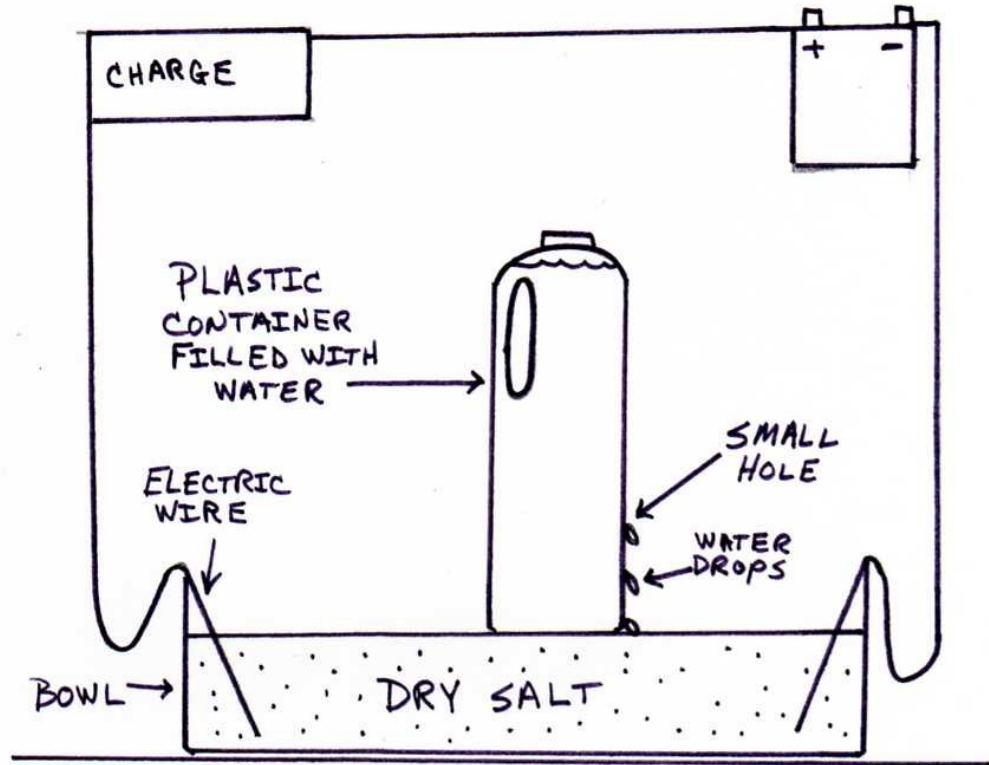

DRY-WET SALT TIME DELAY

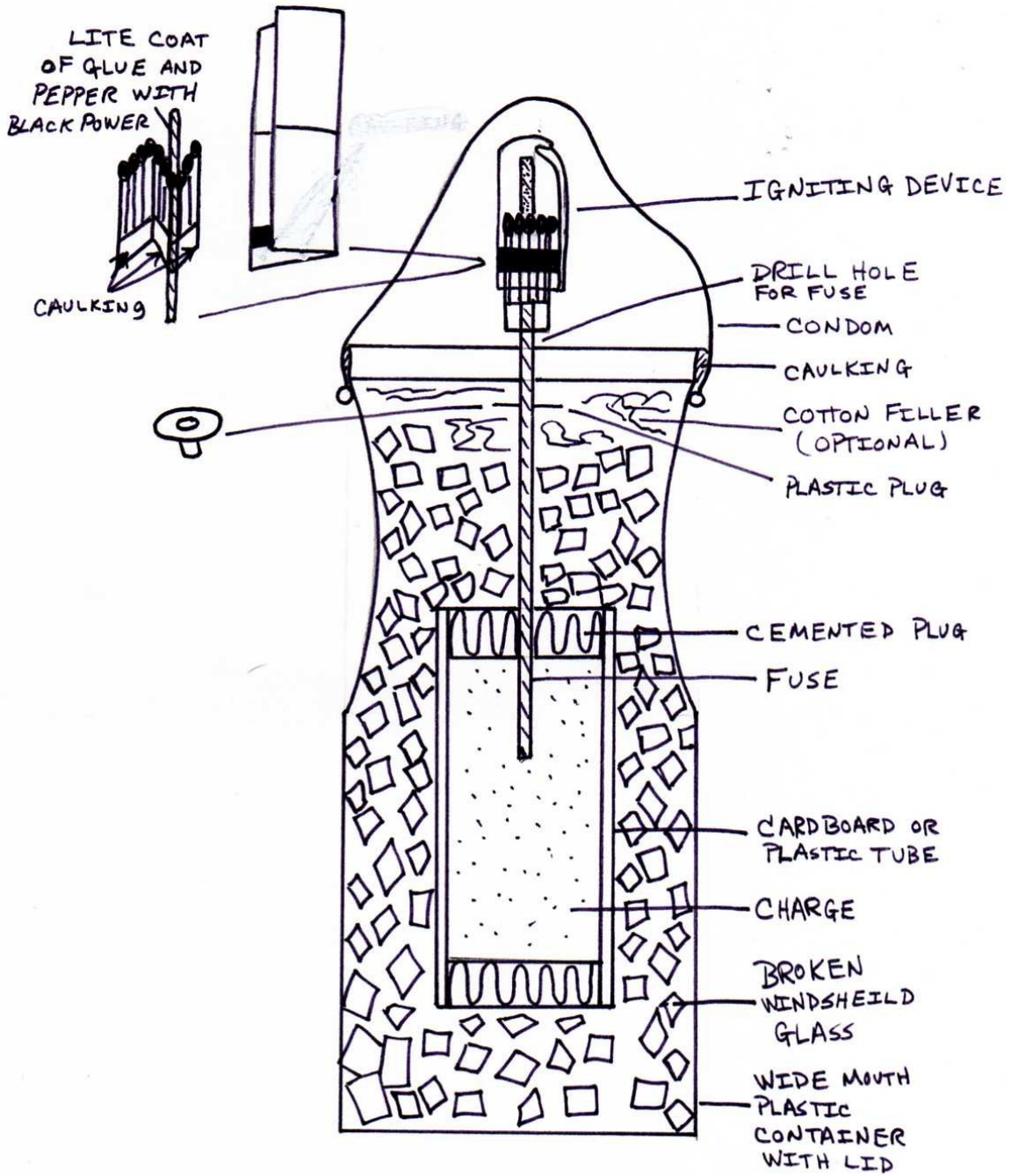

NON-METAL DETECTOR GRENADE

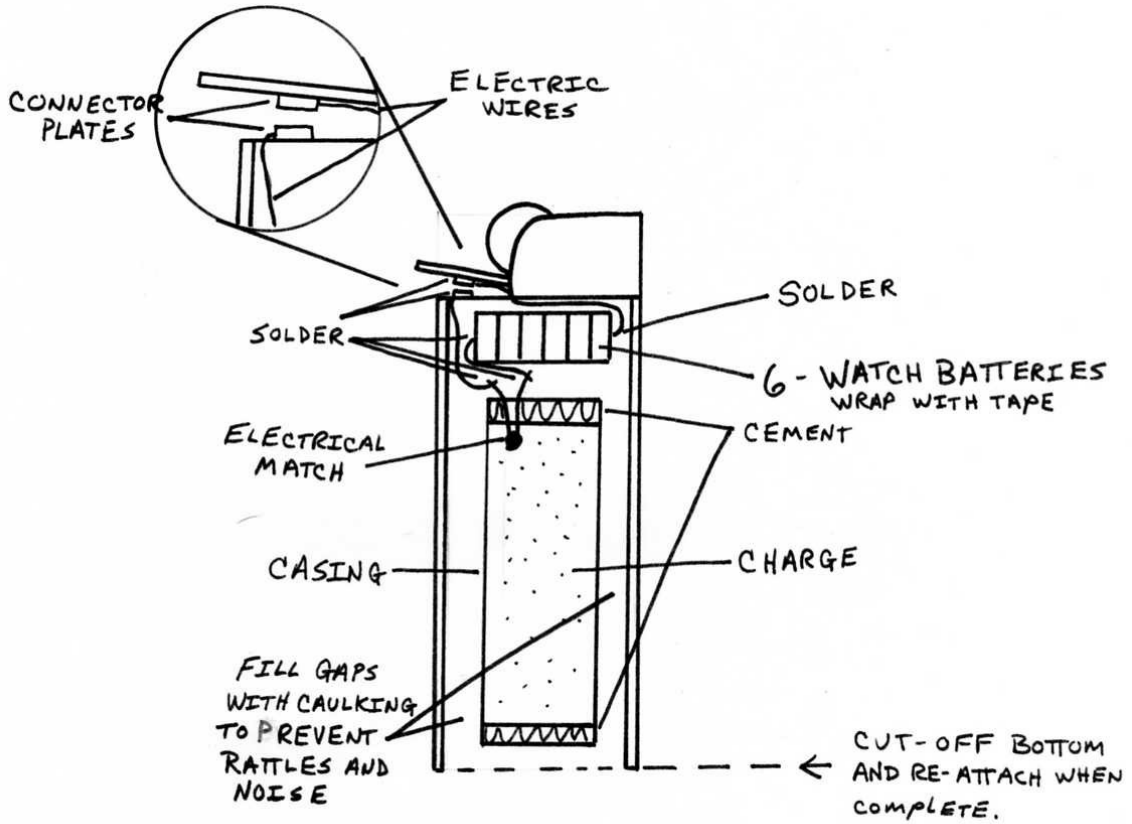

LIGHTER
BIC ~~LEITER~~ BOOBYTRAP

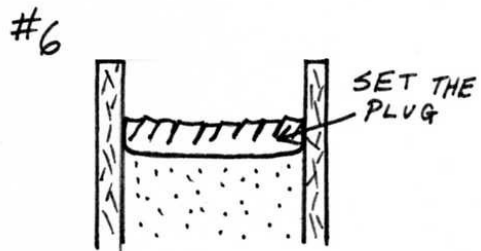
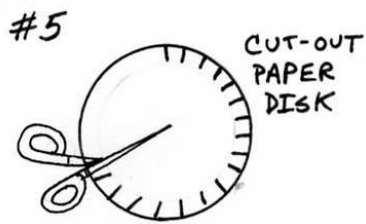
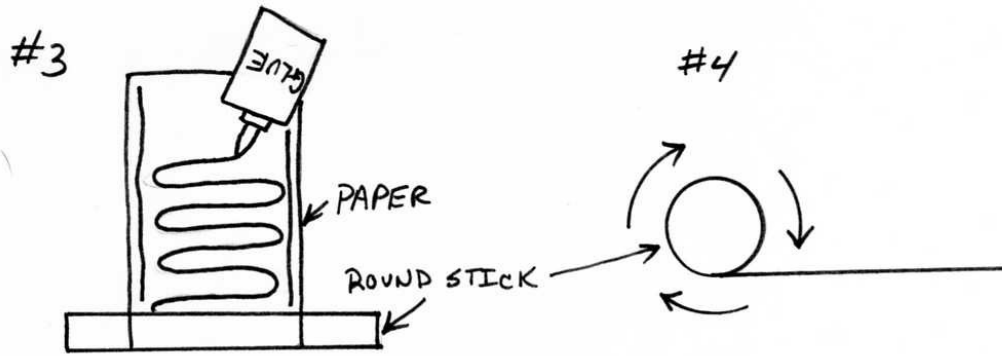
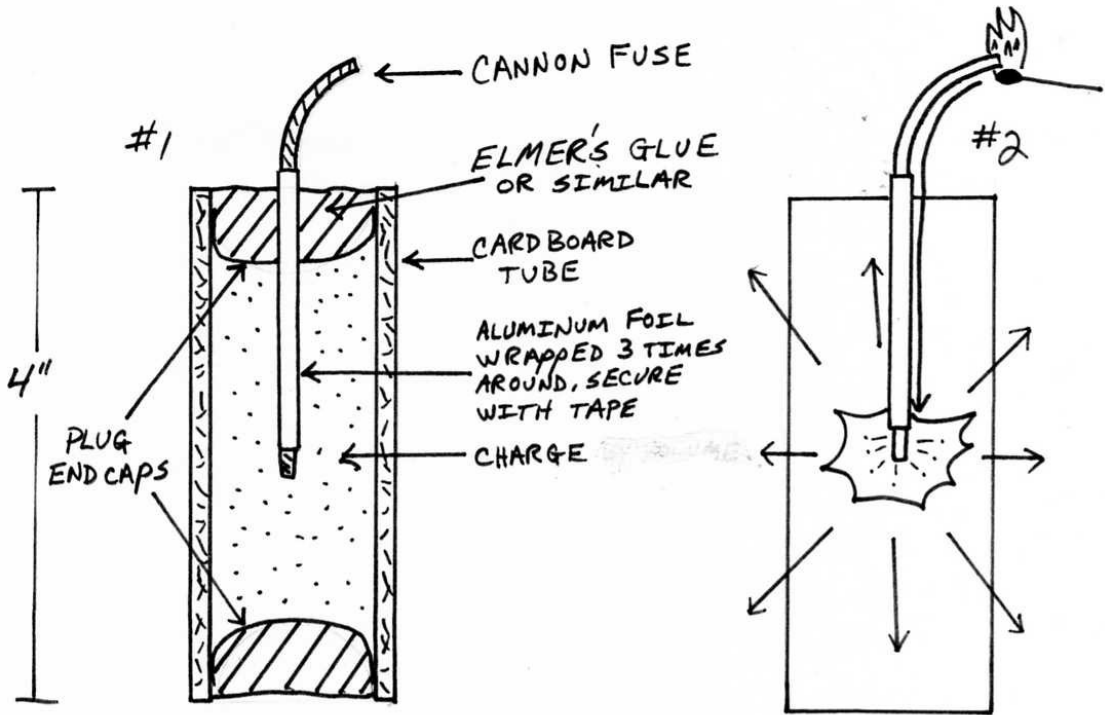

1/4 STICK CHARGE

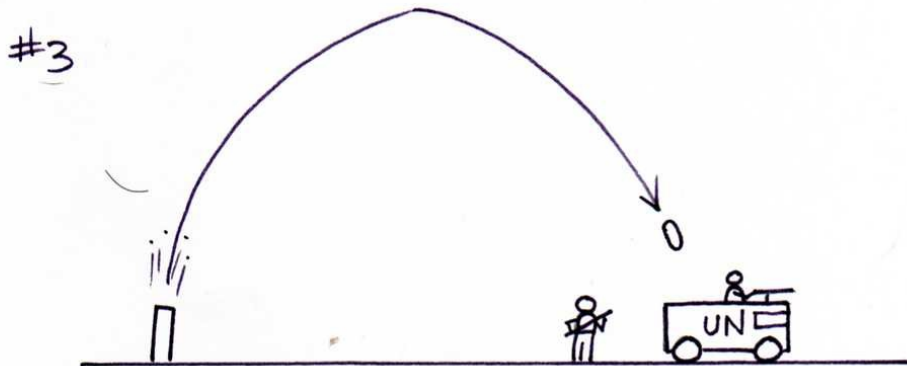
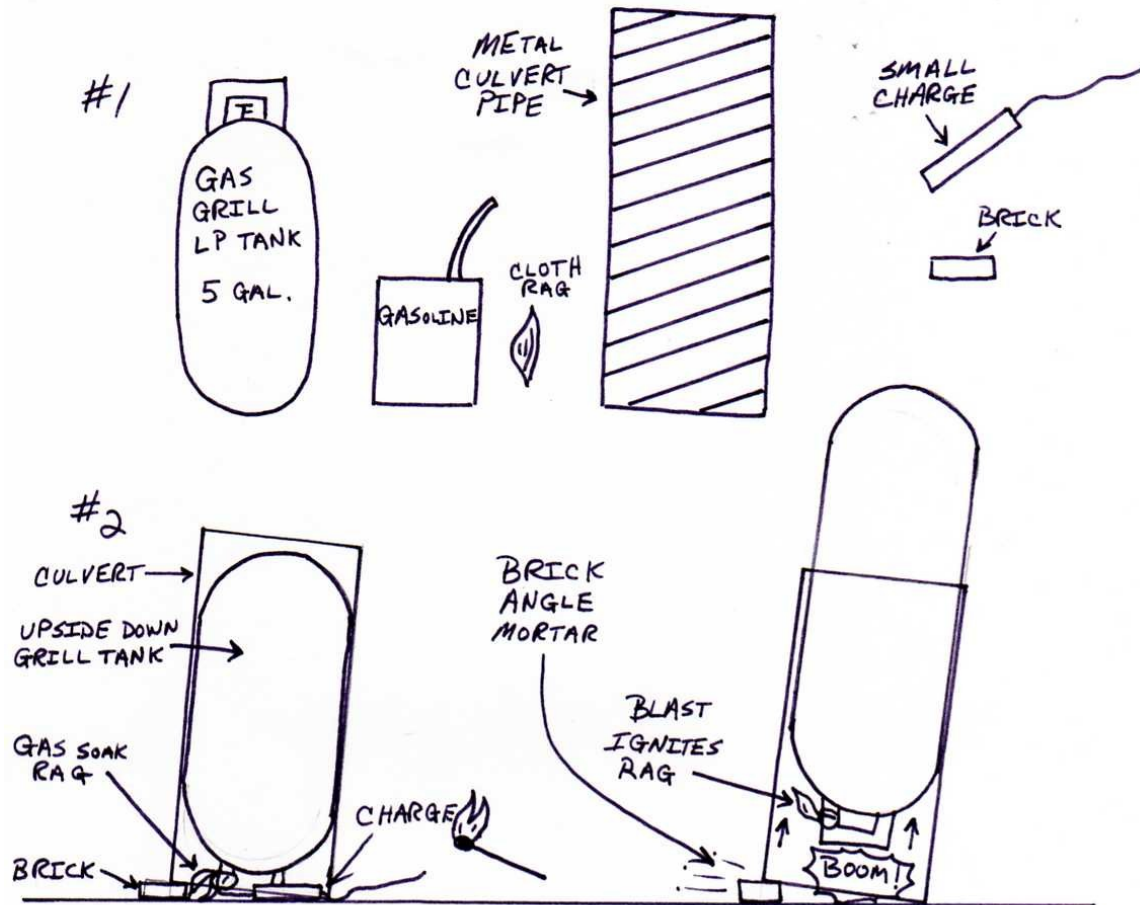

GAS GRILL TANK MORTAR

WARHEAD #3

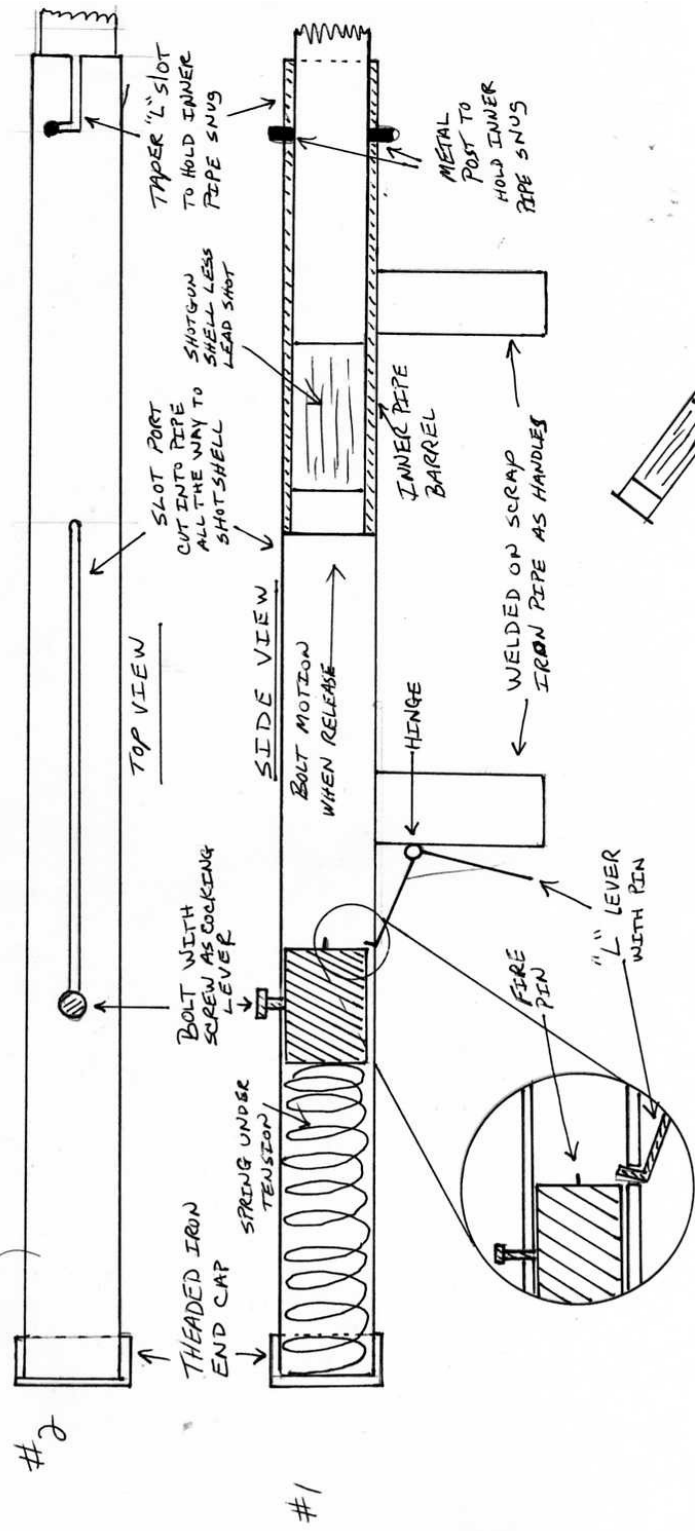
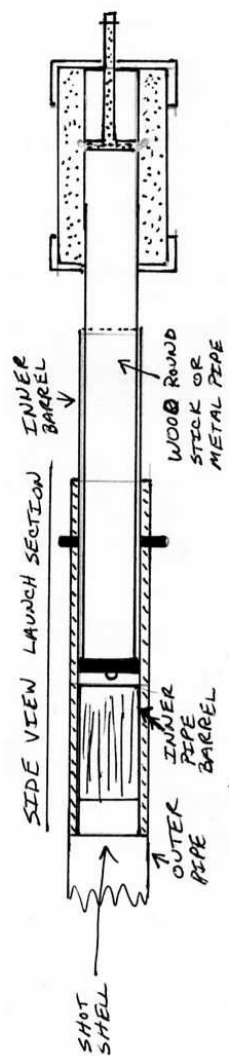

EMPTY LEAD SHOT
OUT OF SHELL AND
RE-CRIMP SHELL

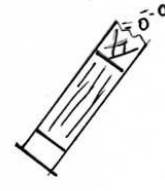

Rocket Propelled Grenade Launcher RPG #1

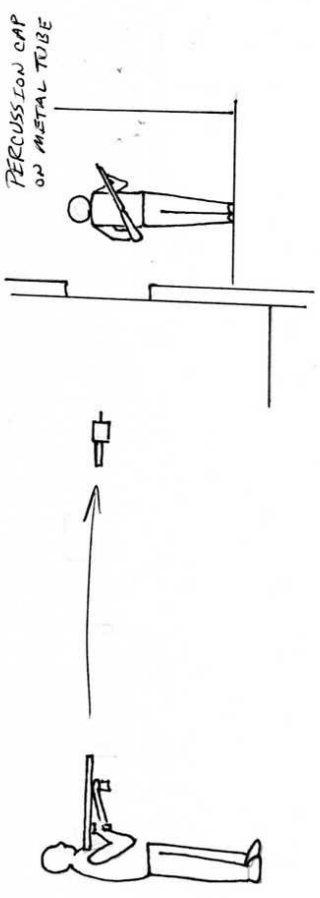
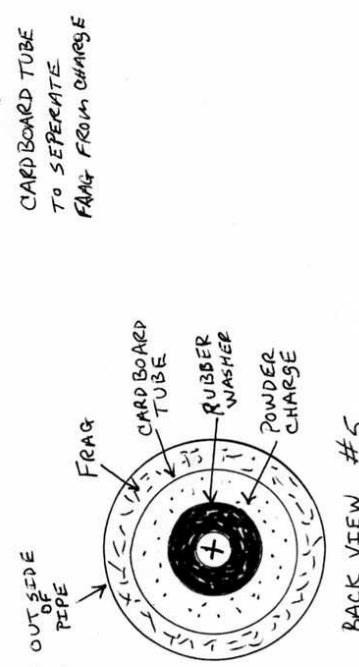
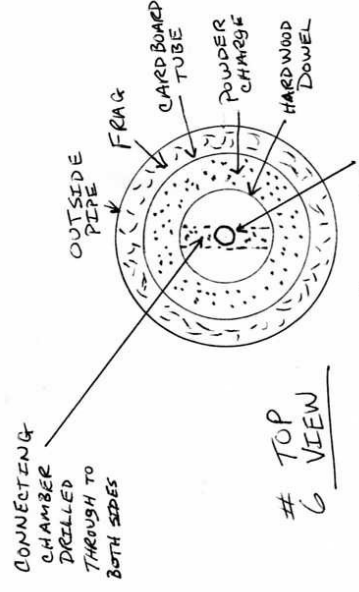
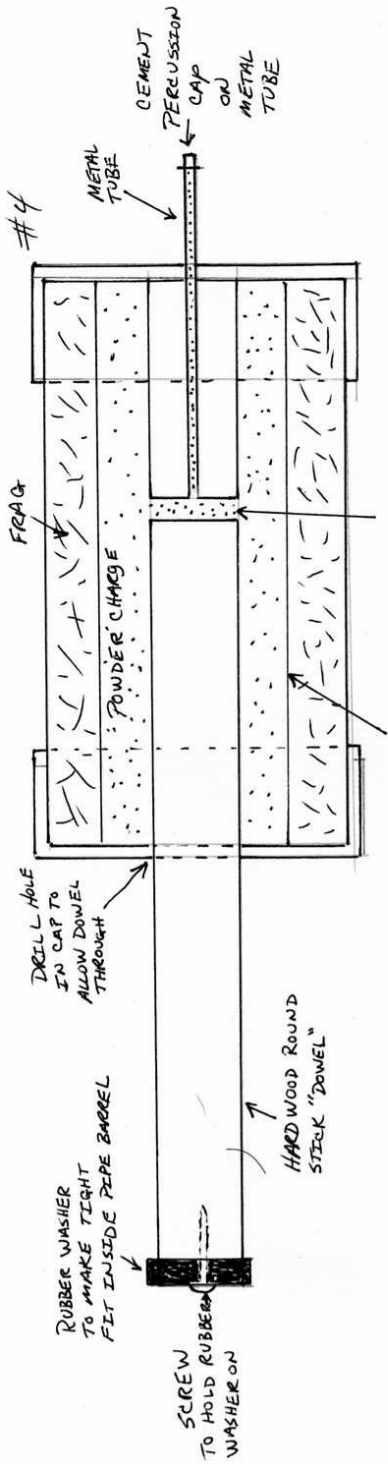

ROCKET PROPELLED GRENADE LAUNCHER RPG #2

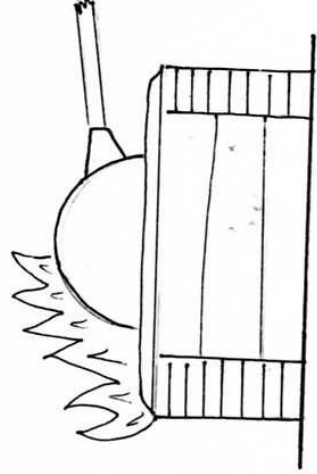
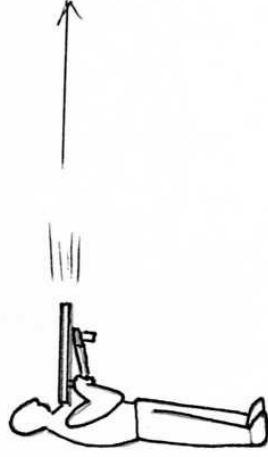
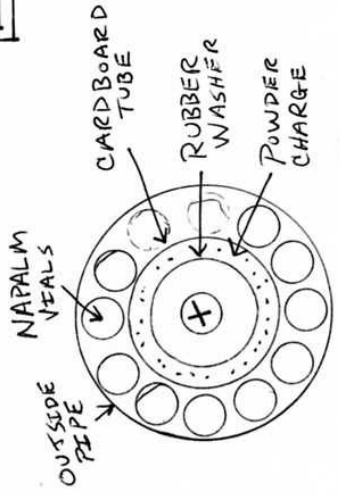
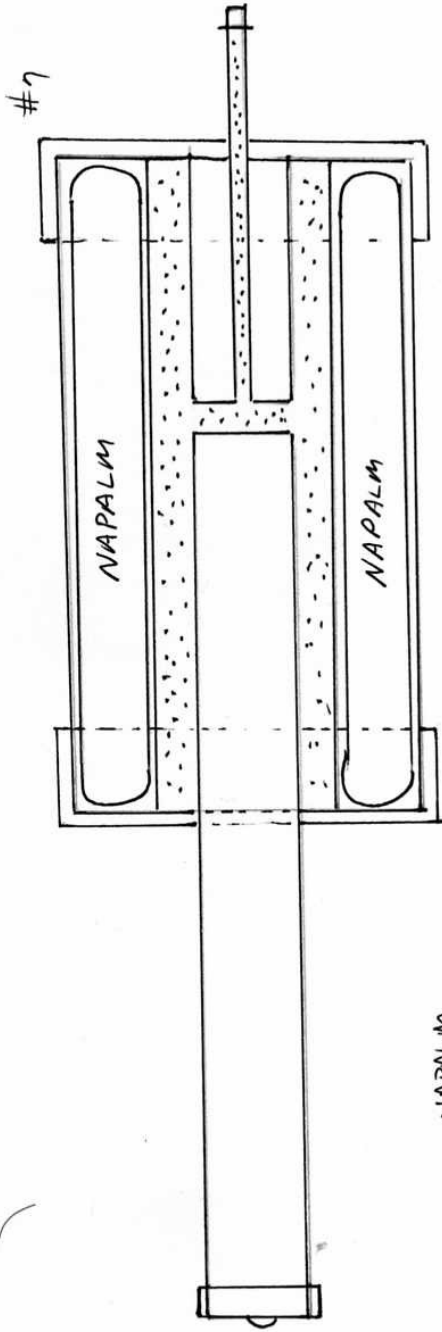

TANK CREWS ARE
TERRIFIED OF FIRE

ROCKET PROPELLED WARHEAD FOR RPG #3

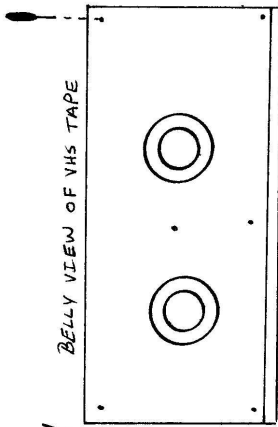

#1

BELLY VIEW OF VHS TAPE

REMOVE ALL SCREWS THEN REMOVE BELLY PLATE TO EXPOSE GUTS. DISCARD GUTS.

#4

FLIP OVER AND SECURE BARE WIRE TO TOP AT ANGLE

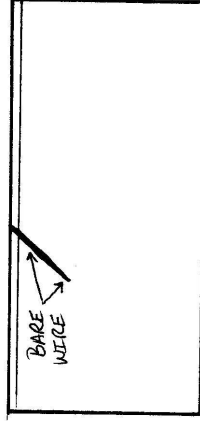

#2

INSTALL CHARGE AND SECURE IN FRAME OF VHS PLATE. STAGER AND INSTALL (4) AA BATTERIES. SOLDER ELECTRICAL WIRE TO THE HEADS AND BASE OF THE BATTERIES AND CONNECT ONE WIRE TO THE ELECTRICAL MATCH HEAD OF CHARGE

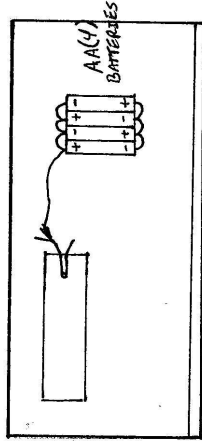

#5

SECURE ANOTHER BARE TIPPED WIRE AT OPPOSITE ANGLE. LEAVE EXTRA WIRE TO CONNECT TO BATTERIES. (DO NOT TOUCH WIRES TOGETHER OR COMPLETE LOOP)

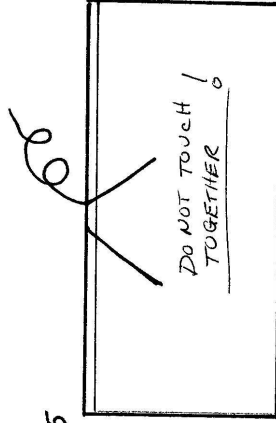

#3

CONNECT OTHER WIRE TO OTHER SIDE OF ELECTRICAL MATCH HEAD. RUN THIS WIRE TO BOTTOM AND SECURE TO VHS PLATE. LEAVE ABOUT 3 INCH EXTRA WIRE

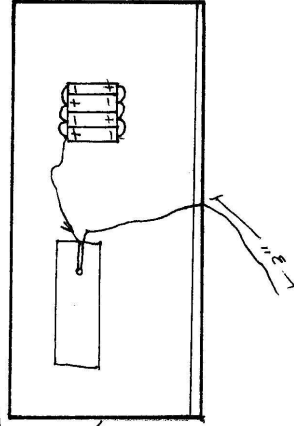

#6

SOLDER LAST WIRE TO BATTERY BANK. IF WIRES ARE TOUCHING, DEVICE WILL EXPLODE ON YOU!

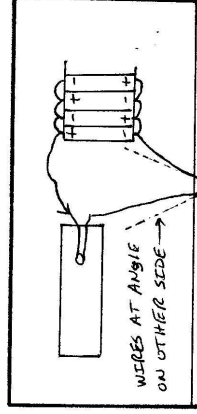

TAPE
VHS BOOBYTRAP #1

#7

RE-ATTACH BELLY PLATE AND INSTALL SCREWS

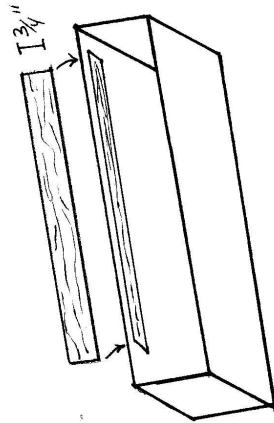
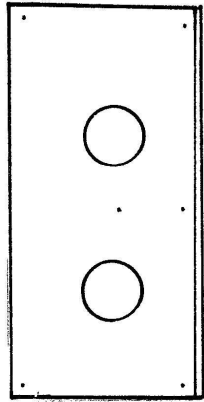

TAPE A STRIP OF FOLDED ALUMINUM FOIL TO THE TOP INSIDE EDGE OF VHS CASE

#8

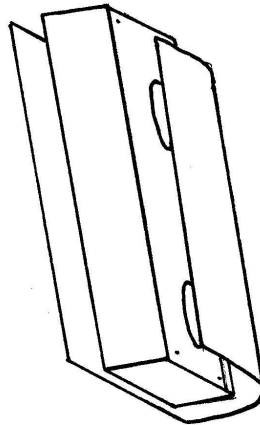

WRAP A SHEET OF NOTE BOOK PAPER AROUND VHS TAPE FROM THE TOP OVER AND AROUND BACK OF VHS TAPE THEN UNDER BELLY PLATE. THE PAPER WILL INSULATE THE BARE WIRE FROM THE ALUMINUM FOIL WHEN INSTALLED INTO CASE

#10

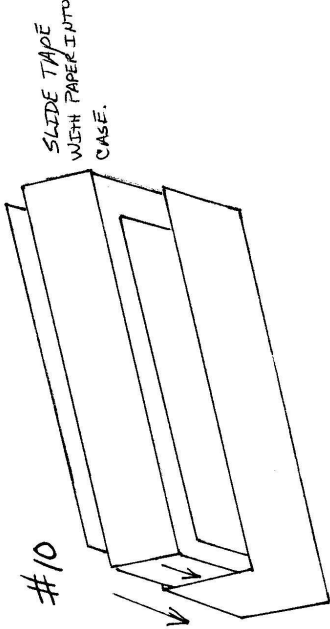

SLIDE TAPE WITH PAPER INTO CASE.

#11

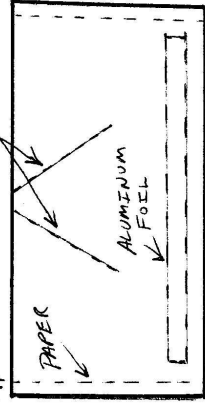

PULL PAPER OUT. IF THE TRIGGER WIRES ARE TOUCHING THE FOIL, IT WILL COMPLETE THE LOOP AND EXPLODE.

PULL PAPER OUT VHS TAPE INSIDE BOX

#12

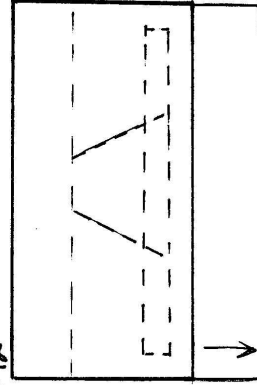

WHEN ATTEMPTING TO REMOVE VHS TAPE FROM CASE, TRIGGER WIRES WILL SLIDE OVER FOIL WHEN COMPLETES LOOP AND EXPLODES.

VHS BOOBYTRAP #2

#1

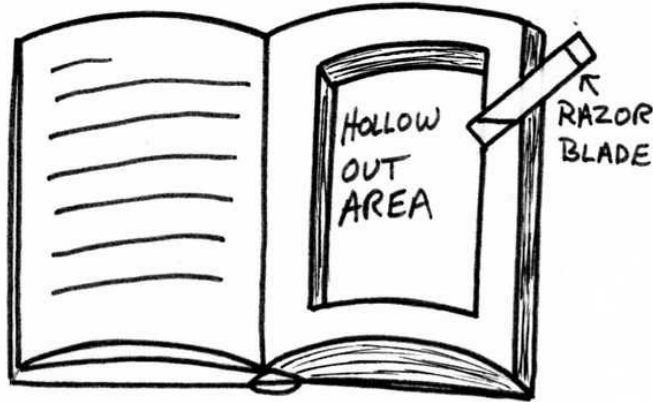

#2

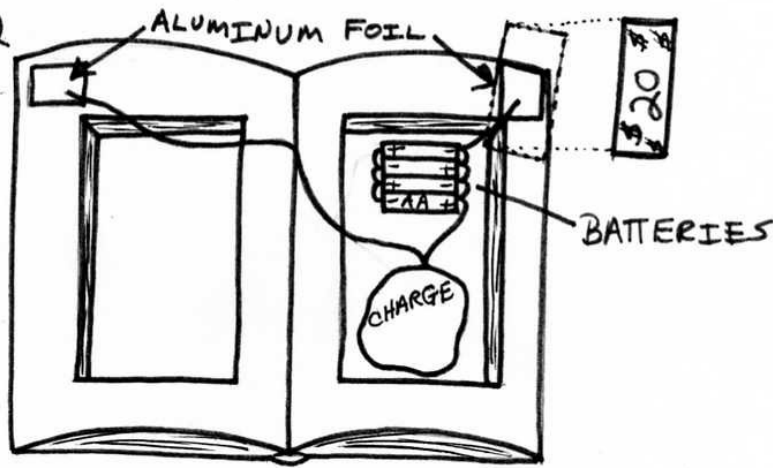

#3

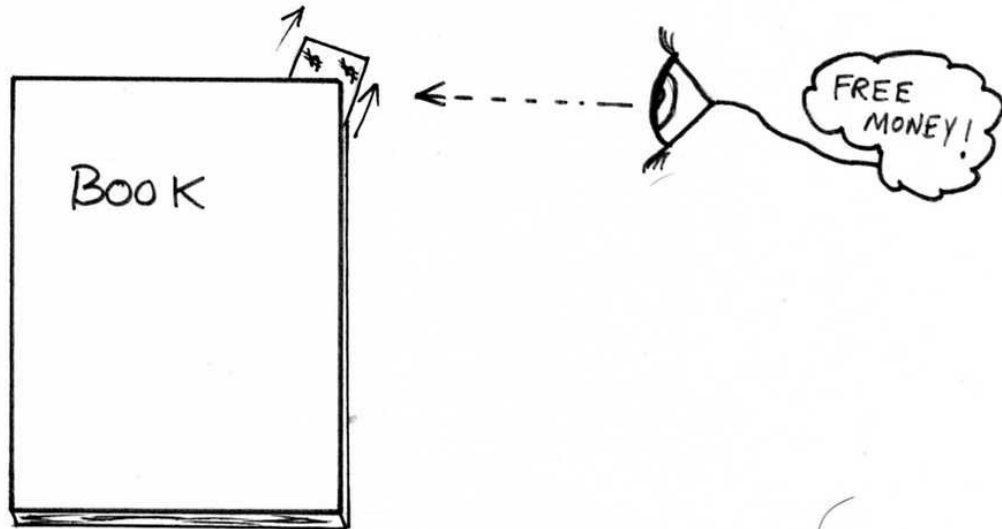

BOOK BOOBYTRAP

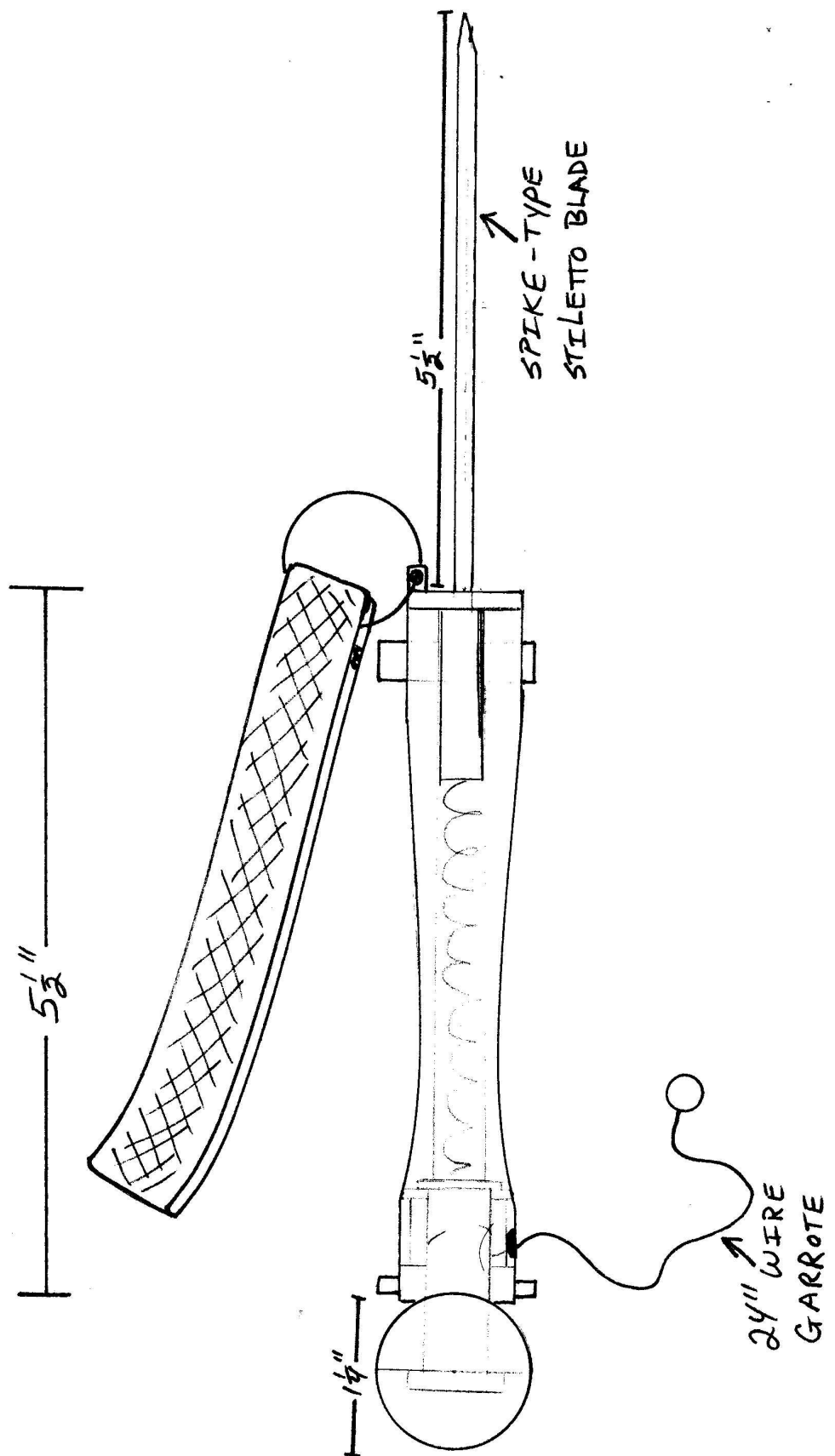

“When, in the course of human events
it becomes necessary for one people...”

WHAT IS THIS NONSENSE?!

